

# Passive Filter Design Can Reduce Harmonics And Add Lighting For Work Convenience

I Ketut Wijaya<sup>1</sup>, I Made Mataram<sup>2</sup>, Kadek Amerta Yasa<sup>3</sup>

<sup>1</sup>Faculty of Electrical Engineering University of Udayana, Badung, Bali, Indonesia.

<sup>2</sup>Faculty of Electrical Engineering University of Udayana, Badung, Bali, Indonesia.

<sup>1</sup>Email: ketutgedewijaya@gmail.com

<sup>2</sup>Email: made\_mmataram@yahoo.com

<sup>3</sup>Department of Electrical Engineering of Bali State Polytechnic Badung, Bali, Indonesia,

<sup>3</sup>Email: amerta.yasa@gmail.com

**Abstract**— Electrical energy is indispensable in people's lives for the sake of survival and for life on the work. Society is now very dependent on electric energy because without the existence of electrical energy the community activity will be stalled.

The loads used in electric energy operations vary widely. Electrical energy operations are severely disrupted due to unbalanced load and nonlinear loads. Unbalanced load and nonlinear loads used for the operation of electrical energy can be disturbing because they produce non-pure sinusoidal waves. THD<sub>i</sub> (harmonics) caused by the unbalance of load and nonlinear load have an impact on electric energy losses and heat on the transformer. THD<sub>i</sub> (harmonics) is caused by unbalance of load and nonlinear load Between Phases RN equal to 7.87%, at SN equal to 3.22%, and at TN 2,41%. After the Passive Filter design is installed THD<sub>i</sub> between Phases becomes smaller that is at RN becomes 1.82%, SN becomes 0.82%, and in TN becomes 0.57%.

THD<sub>i</sub> (harmonics) between phases can be decreased by 76% after Passive Filter is installed. Desain Passive filters are very effective at reducing THD<sub>i</sub> (harmonics) in buildings such as laboratories that use the load of imbalances and nonlinear loads for lab.

**Keyword** : Passive Filter Design, THD<sub>i</sub> (Harmonics), Lighting, Convenience.

## I. INTRODUCTION

The use of electrical appliances is increasingly a top priority and causes more expensive electrical energy. Electrical equipment used in power systems can affect the distribution of electrical energy. Distribution of electrical energy is affected by the unbalanced load and non-linear loads used by consumers. Unbalanced loads and nonlinear loads cause current and voltage THD<sub>i</sub> (harmonics) and they affect electrical energy conditions. The distortion of the current wave and the voltage generated from the imbalance and non-linear load will be formed waves.

The form of current and voltage supplied by an electric power system generator that ideal for the consumer is a pure sinusoid wave. THD<sub>i</sub> (harmonics) is generated by the unbalance of load and the nonlinear load forms an impure wave and causes heat to the distribution transformer. Total Harmonic Distortion (THD) depends largely on the unbalance load and of non-linear load<sup>[3]</sup>. Equipment that uses semiconductor components can be categorized non linear load. The waves generated by the nonlinear load affect the original wave so that the original wave becomes defective and not a sinusoidal wave anymore. Defective waves will cause a decrease in performance on the equipment and will even be damaged. These defective waves can also cause a decrease in fundamental voltage and RMS current on each channel. Defective waves will affect the distribution of electrical energy and cause the phase of the neutral current to be higher exceeds the lowest phase current<sup>[5]</sup>. An enlarged neutral phase can cause power loss in the neutral phase. As a result of high neutral phase will cause power at each phase to different and cause heat, and power losses on the transformer<sup>[10]</sup>. The heat on the transformer will cause the transpormator to be quickly damaged or burned. The existing problem is how to set and prevent heat of transpormator and THD<sub>i</sub> (harmonics) on power electricaly system produced as small as possible. First, the steps that can be done is to reduce the use of equipment that has a high harmonics (load non linear). The second step, namely by adding a filter component to reduce the form of harmonics that occur in the electrical power system in the form wave of voltage and current so that electricity that radiated into more pure / sinusoida.

Research with unbalance load and non linear load is done to get maximum result to reduce harmonic level which arise and have an effect on electrical power system. This study aims to find the effectiveness in reducing harmonics using Passive filters on electric power system effect unbalance of load and non linear load.

### 1.1 Problem Formulation

From the above description can be made problem formulation as follows:

1. What is the level of harmonics that occurs on non-load imbalance and non-linear load?
2. How is the Pasip Filter design for the electrically load available?

*1.2 Research Benefits*

1. To know how to reduce harmonics due to load imbalance and non linear load.
2. It is recommended to all parties through this paper to be able to introduce one way to reduce harmonics because harmonics are dangerous for the continued use of electric power..

**II. MATERIAL AND METODS**

The material in this research is a small system in the laboratory of electric power at the laboratory of Electrical Engineering Udayana University, Bukit Jimbaran, Bali.

The method used is by way of direct measurement and finding sources of standard provisions on the IEEE as a reference in analyzing the results of research obtained.

**III. HOW TO RESEARCH**

1. Preparing the tool to which will used on the research.
2. Conducting research.
3. Record data of current harmonic current (THD<sub>i</sub>) resulting from unbalanced load and nonlinear load.
4. Conduct analysis.
5. If the level of harmonics (THD) exceeds that standardized according to IEEE then do the repair and design Pasif Filters for existing system.

**IV. RESULTS AND ANALYSIS OF RESULTS**

*4.1 Results*

*4.1.1 Measurement Results and Calculation Results*

The results obtained from the measurement of THD<sub>i</sub> at each phase of the study site are:

TABLE 1. Measurement Result Data between Phases R-N (Phase R and Neutral Phase), between Phases S-N (Phase S and Neutral Phase), And between Phases T-N (Phase T and Neutral Phase),

Between Phases	Data	Orde	Ampere (A)		Voltage (V)		Calculation Results		
			% THD <sub>i</sub>	THD <sub>i</sub>	% THD <sub>v</sub>	THD <sub>v</sub>			
R-N	P early=6.83 kw	1	100	24	100	2.8	Q	1223.60	kVAR
	V=219.2 volt	3	5.6	1.9	1	2.3	S	1230.43	kVA
	A=33.3 Amp	5	7	2.4	0.6	1.2	Cos φ	0.96	
	Cos Q=0.96	7	4.2	1.5	0.7	1.5	F	50	Hz
S-N	P early=13.96 kw	1	100	58.7	100	223	Q	2.06	kVAR
	V=223.6 volt	3	5.2	3.5	0.8	1.9	S	14.80	kVA
	A=66.2 Amp	5	3.8	2.2	0.5	1.1	Cos φ	0.95	
	Cos Q=0.95	7	1.6	0.6	0.6	1.4	F	50	Hz
T-N	P early=17.08 kw	1	100	82.2	100	2.8	Q	3.46	kVAR
	V=218.6 volt	3	3.2	2.2	0.4	0.9	S	14.80	kVA
	A=79.2 Amp	5	2.6	1.8	0.4	0.8	Cos φ	0.95	
	Cos Q=0.98	7	1.4	1	0.7	1.6	F	50	Hz

(K.Wijaya, 2017)

*Terms:*

Phases in electric power there are 3 that is phase of R, phase of S, and phase of T with symbol  $3\phi$ .

As for the balance electric power must be installed neutral (phase N).

The R-N phase means the phase of R and Phase N

The S-N phase means the phase of S and Phase N

The T-N phase means the phase of T and Phase N

4.1.2 Results and Results Analysis

4.1.2.1 The Imaginary electric power is obtained from:

$$Q = V \cdot x A \sin \phi \dots\dots\dots(1)$$

$$Q = 1.9 \cdot 2.3 \cdot 0.28$$

$$= 1223.6 \text{ Kvar}$$

The imaginary power electrically that the selected in harmonics is the one is at the order of 3, 5, and 7

4.1.2.2 Formula

To obtain C, L, and R can be used formula:

$$Q_c = P(\tan \phi_1 - \tan \phi_2) \dots\dots\dots(2)$$

$$C(\text{Capacitor}) = \frac{Q_c}{2\pi \cdot f \cdot V^2} \dots\dots\dots(3)$$

$$L(\text{Inductance}) = \frac{1}{(2\pi \cdot f)^2 \cdot C} \dots\dots\dots(4)$$

$$R(\text{Reactance}) = \frac{2}{2\pi \cdot f \cdot C} \dots\dots\dots(5)$$

4.1.2.3 Passive Filter Design Result Calculation

TABLE 2. Passive Filter Design

Between Phases	Orde	Component	Calculation Results		Fundamental Frequency 50 Hz	Voltage (Volt)
R-N	3	C	81.03	uf	150 Hz	219.2
		L	0.09	pH		
		R	26.18	Ohm		
	5	C	81.03	uf	250 Hz	219.2
		L	0.03	pH		
		R	15.71	Ohm		
	7	C	81.03	uf	350 Hz	219.2
		L	0.02	pH		
		R	11.22	Ohm		
S-N	3	C	136.51	uf	150 Hz	223.6
		L	0.15	pH		
		R	15.54	Ohm		
	5	C	136.51	uf	250 Hz	223.6
		L	0.06	pH		
		R	9.32	Ohm		
	7	C	136.51	uf	350 Hz	223.6
		L	0.03	pH		
		R	6.66	Ohm		
T-N	3	C	265.01	uf	150 Hz	218.6
		L	0.3	pH		
		R	8	Ohm		
	5	C	265.01	uf	250 Hz	218.6
		L	0.11	pH		
		R	4.8	Ohm		
	7	C	265.01	uf	350 Hz	218.6
		L	0.05	pH		
		R	3.43	Ohm		

(K.Wijaya, 2017)

4.1.3 Analysis Before Passive Filter Installed

TABLE 3. Results of Analysis Before Passive Filter Installed

Between Phases	Bus		Current Distortion			
	From Bus ID	To Bus ID	Fund Amp	RMS Amp	ASUM Amp	THD %
R-N	Bus 1	Bus 2	1.08	1.09	1.2	7.87
	Bus 2	Bus 1	1.08	1.09	1.2	7.87
		Bus 3	1.08	1.09	1.2	7.87
	Bus 3	Bus 2	1.08	1.09	1.2	7.87
		Bus 4	1.08	1.09	1.2	7.87
	Bus 4	Bus 5	1.08	1.09	1.2	7.87
Bus 3		1.08	1.09	1.2	7.87	
S-N	Bis 1	Bus 2	1.08	1.08	1.13	3.22
	Bus 2	Bus 1	1.08	1.08	1.13	3.22
		Bus 3	1.08	1.08	1.13	3.22
	Bus 3	Bus 2	1.08	1.08	1.13	3.22
		Bus 4	1.08	1.08	1.13	3.22
	Bus 4	Bus 5	1.08	1.08	1.13	3.22
Bus 3		1.08	1.08	1.13	3.22	
T-N	Bis 1	Bus 2	1.08	1.08	1.12	2.41
	Bus 2	Bus 1	1.08	1.08	1.12	2.41
		Bus 3	1.08	1.08	1.12	2.41
	Bus 3	Bus 2	1.08	1.08	1.12	2.41
		Bus 4	1.08	1.08	1.12	2.41
	Bus 4	Bus 5	1.08	1.08	1.12	2.41
Bus 3		1.08	1.08	1.12	2.41	
Bus 5	Bus 4	1.08	1.08	1.12	2.41	

(K. Wijaya, 2017)

4.1.4 Analysis After Installed Passive Filter

TABLE 4. Results of Analysis After Installed Passive Filter

Between Phases	Bus		Current Distortion			
	From Bus ID	To Bus ID	Fund Amp	RMS Amp	ASUM Amp	THD %
R-N	Bus 1	Bus 2	2.65	2.65	2.7	1.82
	Bus 2	Bus 1	2.65	2.65	2.7	1.82
		Bus 3	2.65	2.65	2.7	1.82
	Bus 3	Bus 2	2.65	2.65	2.7	1.82
		Bus 4	2.65	2.65	2.7	1.82
	Bus 4	Bus 5	2.65	2.65	2.7	1.82
Bus 3		2.65	2.65	2.7	1.82	
Bus 5	Bus 4	2.65	2.65	2.7	1.82	
	Bis 1	Bus 2	2.65	2.65	2.67	0.83
	Bus 2	Bus 1	2.65	2.65	2.67	0.83
		Bus 3	2.65	2.65	2.67	0.83

S-N	Bus 3	Bus 2	2.65	2.65	2.67	0.83
		Bus 4	2.65	2.65	2.67	0.83
	Bus 4	Bus 5	2.65	2.65	2.67	0.83
		Bus 3	2.65	2.65	2.67	0.83
	Bus 5	Bus 4	2.65	2.65	2.67	0.83
	T-N	Bis 1	Bus 2	2.65	2.65	2.67
Bus 2		Bus 1	2.65	2.65	2.67	0.57
		Bus 3	2.65	2.65	2.67	0.57
Bus 3		Bus 2	2.65	2.65	2.67	0.57
		Bus 4	2.65	2.65	2.67	0.57
Bus 4		Bus 5	2.65	2.65	2.67	0.57
		Bus 3	2.65	2.65	2.67	0.57
Bus 5		Bus 4	2.65	2.65	2.67	0.57

(K.Wijaya, 2017)

#### 4.1.5 Measurement of light intensity before and after Passive Filter installs

TABLE 5 Results of Light Intensity Analysis before and after Passive Filter installed

Position		Light Intensity (lux)	
		Before Passive Filter Installed	After Passive Filter Installed
Front	Right	135	245
	Left	135	245
Central		155	250
Back	Right	137	245
	Left	138	245
Average		140	246

(K.Wijaya, 2017)

## V. DISCUSION

### 5.1 Harmonic Level Occurred Due to imbalance of load and Nonlinear Load

#### 5.1.1 Harmonic analysis

The result of measurement current of phase to neutral with load imbalance and nonlinear load before installed passive filter at phases : R-N is 33,3 ampere, S-N is 66,2 ampere, and T-N is 79.2 ampere. Unbalanced of load and nonlinear loads resulted in which is quite large THD<sub>i</sub> (harmonic) rate between phases is: R-N of 7.87%, S-N at 3.22%, and T-N at 2.41%. THD<sub>i</sub> (harmonics) produced can cause heat to the other loads. THD<sub>i</sub> that occurs between the R-N phases already exceeds THD<sub>i</sub> permitted according to IEEE standards (5%)<sup>[2]</sup>. THD<sub>i</sub> arising from unbalanced loads and nonlinear loads may cause damage to existing equipment in the laboratory because the equipment in the laboratory is a heat sensitive device (computer)<sup>[1]</sup>.

#### 5.1.2 Passive Filter Design

The Passive Filter Design is designed with data C, L, and R derived from the calculation on load. Passive Filter Design is installed to minimize THD<sub>i</sub> in an effort to create work convenience. Passive Filter Design can reduce THD<sub>i</sub> and increase the light intensity of the lamp. Passive filters installed will reduce power losses and can provide lighter light intensity so there is no need to increase the capacity of the lamp. Passive filter mounted on load in order to muffle THD<sub>i</sub> (harmonics)<sup>[3]</sup>. Passive Filter installed can reduce THD<sub>i</sub> between phases from 7.87 to 1.82 on between phases R-N, from 3.22 to 0.82 on between phases S-N, and from 2.41 to 0.57 on between phases T-N.

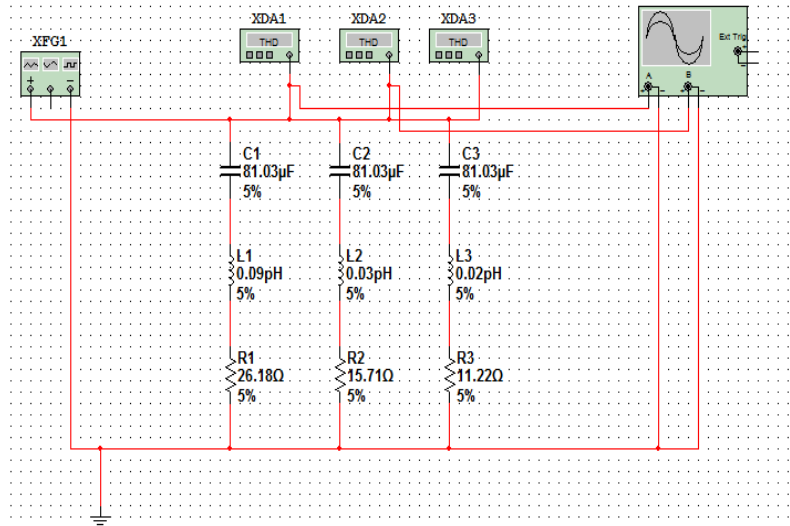

Figure 1. Passive Filter Design between phase R and phase Neutral (K.Wijaya, 2017)

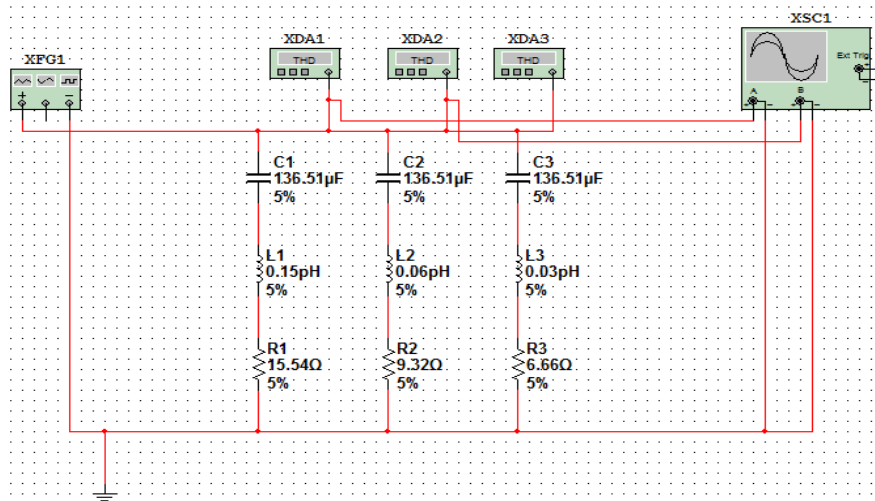

Figure 2. Passive Filter Design between phase S and phase Neutral (K.Wijaya, 2017)

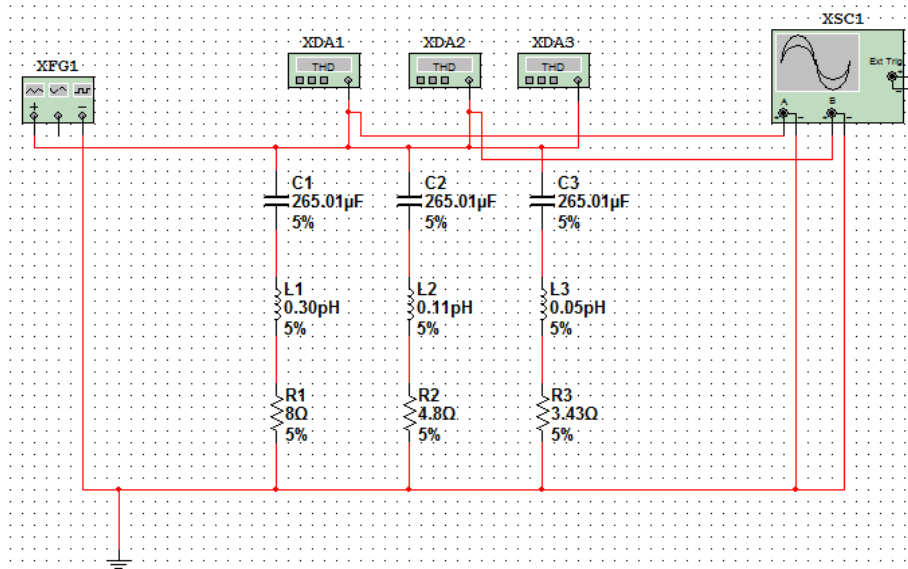

Figure 3. Passive Filter Design between phase T and phase Neutral (K.Wijaya, 2017)

*Terms:*

1. XCS is an oscilloscope
2. XDA is tool of distortion analysis
3. XFG is Function Generator

*5.1.3 Effectiveness of Passive Filter Installation in Reducing Harmonics arising Due to imbalance of load and nonlinear load.*

Reducing the occurrence of harmonics is necessary to be more stable in distributing electric power. Harmonics due to unbalanced loads and nonlinear load can generate heat in the channel and between bus. The heat that arises can affect the condition of the equipment used. Passive Filter installed can reduce THD<sub>i</sub> to 76%<sup>[3]</sup>. Passive filter after installed is very effective to reduce THD<sub>i</sub>. Passive filters can increase the voltage on the buses that decrease due to load imbalance and nonlinear loads<sup>[4]</sup>. After passive filter installed will can decrease THD<sub>i</sub> (current harmonics) between buses. Passive Filter good to installed for installation on power systems with unbalanced load conditions and nonlinear loads<sup>[4]</sup>. Passive Filter installs cause an increase in RMS current and the Fundamentan voltage between buses. The Bus Voltage at the early load decreases and after the Passive Filter is installed it becomes increased so that the installation of an effective Passive Filter is installed to overcome THD<sub>i</sub> (harmonics).

*5.1.4 Lighting*

Passive filters provide an advantage on working conditions by increasing the flow electric of power on the lamp load through a measurement. The electric current after Passive Filter is installed will have an effect by increasing the intensity of the light on the lamp. The intensity of light on the lamp is measured at 5 point of angle (in front that is: right-left, and back that is: right-left, and middle). The intensity of the light is measured at a 5-point angle (on the right front, left, middle, and left right back). Initial light intensity has a mean of 140 lux and after mounted passive filter the lamp has a light intensity with a mean of 246 lux. The 246 lux light intensity meets the requirements for working conditions<sup>[6]</sup>. The intensity of light in working conditions can affect work and can reduce eye fatigue. The intensity of light is higher then the eyes will be able to see the writing with brighter. The intensity of light becomes higher due to the power quality becomes better will affect the light intensity. The greater the intensity of the light the more obvious it can see the objects around<sup>[8]</sup>.

*5.1.5 The principle of ergonomics*

The principle of ergonomics can be applied to the installation of electrical installations by designing and installing Passive Filters together with the installation of electrical installations. The load imbalance that occurred can be overcome early by installing the design of electrical installation well by setting the phase load in a balanced manner. Installation of the overall design is done as early as possible in order to reduce the larger costs to be incurred<sup>[7]</sup>. If repairs are made after the installation of a electrical power it will provide an additional cost. Ergonomics provides advice to work effectively and efficiently. Ergonomics hope for all humans can work naturally without having to work accident accidents resulting from lack of light intensity in the workspace<sup>[6]</sup>.

*5.1.6 Updates Retrieved from Title*

Passive Filter Design can be done where the problem unbalance of load and nonlinear load which cause THD<sub>i</sub> (harmonics) to be high. This design method has a way of minimizing THD<sub>i</sub> in quite effective condition. Passive filter design is a simple but effective way use to make electrical power system installation better and convenient from THD<sub>i</sub> (Harmonics) and can be applied in places where unbalances load and nonlinear load occur in electrical power system. Passive Filter Design can be developed according to the condition of existing power system.

**ACKNOWLEDGMENT**

The recognition was given by Prof. Dewa Sutjana (Udayana University) and Prof. I Made Sutajaya (University of Ganesha Singaraja) and thank You to all.

**CONCLUSION**

Conclusions can be made as follows:

1. Passive Filter Design by using the load data calculation results can reduce THD<sub>i</sub> (harmonics) and can increase the RMS current and the fundamental voltage so as to reduce the loss of electrical energy. Fundamental Voltage Improvement will affect the increase of light intensity on the lamp. Increased light intensity occurred from 140 lux increased to 246 lux. The intensity of 246 lux light is enough to do activities in the room.
2. If the Passive Filter design is installed at the beginning of the installation then it will be better for aesthetics and more effective and efficient in usage.
3. Passive Filter Design is effective enough to reduce THD<sub>i</sub> (harmonics) is proven to reduce THD<sub>i</sub> harmonics by 76%.

## REFERENCES

- [1] Edy Sumarno, Syaiful Bakhri. 2014. Analysis of the Influence of Unbalanced Expenses on Harmonics on the Three-phase Speed Drive Phase Three. Electrical Power and Controls, New Jersey: Prentice Hall. , Skvarenina, Timothy L. and William E, DeWitt., (2004).
- [2] IEEE Std. 519-1992., 1994, IEEE Guide for Harmonic Control and Reactive Compensation of Static Power Converter. Internet.
- [3] Study Harmonics of Flows and Electricity Voltage in Building Administration Pontianak State Polytechnic. Vocational Journal Volume 8, Number 2, June 2012. ISSN 1693 - 9085 pages 80 – 89.
- [4] Ismail Cumentas, Waluyo, Nasrun Hariyanto, 2013. Analysis of the Influence of Unbalance of the Load Condition on Harmonic Flow and Three-phase Sync Power Factor. Journal Reka Elkomika.TeknikElektro | Itenas | Vol.1 No.3. ISSN 1693 – 9085 hal 80 – 89.
- [5] I Wayan Suwardana, I Putu Sutawinaya and I Ayu Rai Wulandari, 2014. Study of Analysis of Power Loss Loss on neutral Wire Due to Unbalanced Systems in Distribution Networks Substation KA 1495 Censorship Citraland Using Simulation Program ETAP 7.0. JOURNAL LOGIC. VOL. 14. NO. 3. NOVEMBER 2014.
- [6] K. Wijaya, 2012. Word Effect Of Temperature, The Lighting, Workload, Noise Against Eye Fatigue, General Fatigue And Stress Affect Learning Outcomes The Student Computer Users. International Journal of Computer Applications (0975 – 8887) Volume 58– No.5, November 2012. Terindek Google Scholar, CiteSeer, DOAJ, and ProQuest.
- [7] K. Wijaya, 2015. Method Enlarge Intensity Illumination Without Adding Power Electricity. International Journal of Engineering and Technology (IJET). ISSN : 0975-4024, Vol 7 No 2 Apr-May 2015, hal. 749-752. Indexed by SCOPUS.
- [8] K. Wijaya, 2015. Methods Decrease Electric Field Computer The Using Size Anthropometric Distance Body User. International Journal of Engineering and Technology (IJET). ISSN : ISSN : 0975-4024, Vol 7 No 5 Oct-Nov 2015, hal. 1867-1872. Indexed by SCOPUS.
- [9] K. Wijaya, 2017. Data on Research Results from January to October 2017.
- [10] Moh. Dahlan .2013. Due to Unbalanced Load to Current of Neutral And Losses On Distribution Transformer. Journal. ISSN: 1979-6870.

## AUTHOR PROFILE



I Ketut Wijaya was born : in Padangbai, Karangasem, Bali, Indonesia. Date: October 12, 1959. Education : Education Strata 1: Institute of Technology Surabaya in Surabaya, Indonesia and Acquired degree which is Ir, 1986. Education Strata 2: Ergonomics of Work Physiology Udayana University in Denpasar, Bali, Indonesia, and degree which obtained is M.Erg (Master Ergonomics), 2007. Education Strata 3: Ergonomics of Work Physiology Udayana University in Denpasar, Bali, Indonesia, and degree which obtained is Dr (Doctor), in 2011. Often participated in the training, the writing and research national nor international. Worked as a lecturer at the Faculty of Electrical Engineering University of Udayana Badung, Indonesia from 1987 to the present.



I Made Mataram was born : in Takmung, Klungkung, Bali, Indonesia. Date: August 20, 1965. Education : Education Strata 1: Institute of Technology Surabaya in Surabaya, Indonesia and Acquired degree which is Ir, 1990. Education Strata 2: Ergonomics of Work Physiology Udayana University in Denpasar, Bali, Indonesia, and degree which obtained is M.Erg (Master Ergonomics), 2004. Education Strata 2: Institute of Technology Surabaya in Surabaya, Indonesia and Acquired degree and degree which obtained is M.T (Magister Teknik), in 2007. Often participated in the training, the writing and research national nor international. Worked as a lecturer at the Faculty of Electrical Engineering University of Udayana Badung, Indonesia from 1991the present.



Kadek Amerta Yasa was born : in Denpasar, Bali, Indonesia. Date: September 12, 1968. Education : Education Strata 1: Udayana University in Denpasar, Indonesia and obtain a degree is ST, 1994. Education Strata 2: Electrical Engineering of Udayana University in Denpasar, Bali, Indonesia, and degree which obtained is MT (Master Technic), 2011. Worked as a lecturer at the Departmen of Electrical Engineering of Bali State Polytechnic Badung, Indonesia from 1995 to the present.