



Adi Winarta <artawina@gmail.com>

IMPORTANT i-TREC 2017: Missing Abstract Online and Full Paper Submission Reminder

Adi Winarta <artawina@gmail.com>
To: nandyputra@eng.ui.ac.id

Sat, Sep 2, 2017 at 4:42 PM

berikut, submit paper ke I-trec prof

[Quoted text hidden]

2 attachments

 **Adi Winarta-ITREC_Abstract ID_9312.doc**
1787K

 **Abstract-Adi Winarta-ITREC_Abstract ID_9312.doc**
31K



UNIVERSITAS
INDONESIA

Veritas, Probitas, Justitia

FAKULTAS

TEKNIK

THE 2nd INTERNATIONAL TROPICAL RENEWABLE ENERGY CONFERENCE (i-TREC)



OCTOBER 3-4, 2017 | COURTYARD BY MARRIOTT NUSA DUA, BALI INDONESIA

Letter of Acceptance

Jakarta, September 6, 2017

Ref: 13037/LoA/i-TREC/2017

Dear Prof/Dr/Mr/Mrs. Adi Winarta

The 2nd International Tropical Renewable Energy Conference (i-TREC) 2017 Editorial Committee has completed the reviewing process and we are pleased to inform you that your manuscript,

Title : A Preliminary Investigation on Visualization of Oscillating Heat Pipe with Non Destructive Test

Paper ID : 13037

Author(s) : Adi Winarta

Has been ACCEPTED for inclusion as ORAL presentation in the 2nd International Tropical Renewable Energy Conference (i-TREC) 2017 symposium program. For inclusion in the conference proceeding we require that you revise the full paper according to the reviewers' comments (see below). The authors are then requested to submit their camera ready full paper by September 30, 2017 along with the signed Copyright Form. Information on the camera-ready paper submission is available at <http://i-trec.ui.ac.id/>. Please follow the specific requirements accordingly.

The program schedule of each session will be posted on i-TREC 2017 Website. One of the authors MUST attend and present their paper in order to be included in SCOPUS indexed journal/proceeding (selected paper only). Papers that are not presented in the symposium will be excluded from the i-TREC publications. Presenting authors MUST register by September 25, 2017 to securely place their program by sending their filled registration form to i-TREC.

A Rp. 800.000,00 (US\$ 60) /paper additional fee would be applied for any paper recommended to be published in IoP with the page between 5-6 pages. Any paper with more than 6 pages would be charged US\$ 50/page.

The fee amount for recommended paper in IJ-Tech Journal is Rp. 2.000.000 (US\$ 160)/ paper, and the paper need to be expanded to 8-10 pages. If your paper is recommended for IJ-Tech Journal, you have the option to published it in IoP, but NOT vice versa.

The additional cost for this publication should be paid before or during the 2nd i-TREC 2017 conference registraton, at the latest.



UNIVERSITAS
INDONESIA

Veritas, Probitas, Justitia

FAKULTAS

TEKNIK

THE 2nd INTERNATIONAL TROPICAL RENEWABLE ENERGY CONFERENCE (i-TREC)



OCTOBER 3-4, 2017 | COURTYARD BY MARRIOTT NUSA DUA, BALI INDONESIA

We appreciate your participation and look forward to welcoming you to the 2nd International Tropical Renewable Energy Conference (i-TREC) 2017 in Bali, October 3-4, 2017.

Conference Organizing Committee

Eny Kusriani, Ph.D.
General Chair



UNIVERSITAS
INDONESIA
Veritas, Probitas, Justitia

FAKULTAS

TEKNIK

THE 2nd INTERNATIONAL TROPICAL RENEWABLE ENERGY CONFERENCE (i-TREC)



OCTOBER 3-4, 2017 | COURTYARD BY MARRIOTT NUSA DUA, BALI INDONESIA

Revision:

GENERAL	Many mistakes type and need to make clear statement s
ABSTRACT	OK
INTRODUCTION	OK
METHODOLOGY	Improve some statements
RESULTS AND DISCUSSION	Have to make clearly explanations
REFERENCES	OK

Publication :

Published in IoP Conference Series: Earth and Environmental Sciences (EES)	X
Published International Journal of Technology	



Adi Winarta <artawina@gmail.com>

[i-trec2017] ACCEPTANCE LETTER FULL PAPER

i-TREC Committee <mailer@ui.ac.id>
Reply-To: i-TREC Committee <i-trec@ui.ac.id>
To: Mr Adi Winarta <artawina@gmail.com>
Cc: eny2kus@yahoo.com

Sat, Sep 16, 2017 at 4:35 PM

Dear Prof/DR/Mr/Ms. Adi Winarta

Please find attached the Acceptance Letter for your fullpaper, IJ-Tech template, and IoP format to join the 2nd i-TREC 2017.



Thank you very much for your kind contribution and we are looking forward to see you soon at the conference.

Warmest Regards,

The 2nd i-TREC 2017 General Chair

The 2nd International Tropical Renewable Energy Conference
<http://conference.ui.ac.id/itrec/i-trec2017/index>

3 attachments

-  **Acceptance Letter Paper Id 13037.pdf**
340K
-  **fulltexttemplate_IOP_EES.doc**
971K
-  **ijtech_template.doc**
466K



Adi Winarta <artawina@gmail.com>

paper revisi i-trec

Adi Winarta <artawina@gmail.com>
To: nandyputra@eng.ui.ac.id

Wed, Sep 27, 2017 at 4:34 AM

Berikut saya lampirkan revisi dari koment reviewer i-trec.
mohon masukannya prof. Terima kasih sebelumnya prof

Best Regards

adi winarta

2 attachments **Adi Winarta-ITREC_Abstract ID_9312_27 Sept revision.doc**
1794K **Acceptance Letter Paper Id 13037.pdf**
340K



Adi Winarta <artawina@gmail.com>

paper revisi i-trec

nandyputra@eng.ui.ac.id <nandyputra@eng.ui.ac.id>
To: Adi Winarta <artawina@gmail.com>

Wed, Sep 27, 2017 at 11:47 PM

ok kirim

[Quoted text hidden]

[Quoted text hidden]

--

This message has been scanned for viruses and dangerous content by **MailScanner**, and is believed to be clean.



Adi Winarta <artawina@gmail.com>

Paper yang sudah direvisi

Adi Winarta <artawina@gmail.com>

Wed, Sep 27, 2017 at 11:27 PM

To: i-TREC 2016 <i-trec@ui.ac.id>

Kepada Yth Bapak/Ibu
Panitia I-Trec UI

Berikut saya kirimkan full paper yang sudah kami perbaiki (termasuk perubahan template) sesuai dengan hasil review dan rekomendasi publikasi. Sekian dan terima kasih

Regards

Adi Winarta
ID 9312



Adi Winarta-ITREC_Abstract ID_9312_27 Sept revision.doc

1794K



Adi Winarta <artawina@gmail.com>

IMPORTANT i-TREC 2017: Missing Abstract Online and Full Paper Submission Reminder

Adi Winarta <artawina@gmail.com>
To: i-TREC 2016 <i-trec@ui.ac.id>

Mon, Aug 28, 2017 at 9:10 AM

Dear i-TREC Committe

I attach my full paper below. Thanks

Regard

Adi Winarta
Abstract ID:9312
[Quoted text hidden]

 **Full_Paper_Adi Winarta_ITREC.doc**
3531K



Adi Winarta <artawina@gmail.com>

IMPORTANT i-TREC 2017: Missing Abstract Online and Full Paper Submission Reminder

Adi Winarta <artawina@gmail.com>
To: i-TREC 2016 <i-trec@ui.ac.id>

Wed, Aug 30, 2017 at 9:59 AM

Dear I-Trec Committe

Herewith I send again the abstract and Full Paper (Final) for the 2nd i-TREC 2017 Conference. Please update my submission paper with this final document.
Thanks for your kindness and attention.

Best Regard

Adi Winarta
Abstract ID:9312

On Sat, Aug 26, 2017 at 1:31 PM, i-TREC 2016 <i-trec@ui.ac.id> wrote:

[Quoted text hidden]

2 attachments



Adi Winarta-ITREC_Abtract ID_9312.doc
1787K



Abstract-Adi Winarta-ITREC_Abtract ID_9312.doc
31K

A Preliminary Investigation on Visualization of Oscillating Heat Pipe with Non-Destructive Test

Adi Winarta¹, Nandy Putra^{1*}, Iwan Sumirat², Fahrurrozi² and Bharoto²

¹*Applied Heat Transfer Research Group, Department of Mechanical Engineering Universitas Indonesia, Kampus Baru Depok, 16424*

²*Centre of Science and Technology of Advanced Materials, National Nuclear Energy Agency of Indonesia (BATAN), Indonesia*

*E-mail : nandyputra@eng.ui.ac.id

Abstract. Oscillating Heat Pipe (OHP) is a passive heat exchanger operating on two phase flow principle. As one of the newest members of the heat pipe family, OHP has a complicated operating mechanism of working fluid flow. OHP is a potential device, which can be used for saving energy and cost. Although, OHP is a promising two-phase heat transfer device with excellent performance, simple structure and low cost but its operational characteristic is still not clear yet and debatable. As one of the non-destructive test, neutron radiography uses neutron beam techniques to penetrate heavy materials while beam are absorbed by lighter materials. This method is very suitable for use in visualization technique of the two-phase flow of heat transfer device with hydrogen-based fluids. In this paper, the visualization method is coupled with thermocouple temperature measurement. Aluminium OHP with 12 turns has been manufactured and tested. The dimension of aluminium OHP is made fit with the neutron beam size. DI Water with filling ratio 35 % has been chosen as the working fluid for the close loop OHP. Three level of heating power was applied to the evaporator section of OHP. The result showed that this preliminary study could reveal the temperature fluctuation of the thermocouple data. The condensation and evaporation also can be observed adequately with this method.

1. Introduction

Oscillating Heat Pipe (OHP) is one of the recent types of heat pipe family which has found by Akachi in the earlier 1990 [1]. Besides the high possibility of electronic cooling application for next thermal management device, OHP also has a good prospect in the heat recovery technology [2–4], solar energy [5] and much more [6].

OHP is made from a capillary tube which then bent forming many turns as snake shape model. It's structure typically either as a closed or open loop configuration. At one end of that meandering tube is called evaporator and the opposite turns called the condenser. The evaporator and condenser section typically connected by adiabatic part. The use of capillary tube is the most important characteristics of OHP [6]. It is characterized using the Bond Number (Bo) of working fluid properties. Which is $Bo = (\rho_l - \rho_v)gD^2/4\sigma$, where ρ_l and ρ_v are liquid and vapor density respectively, g is gravity, D is tube diameter and σ is a surface tension. If Bo number is lower than 4 then it could be said that the surface tension force is dominant than the gravitational force. As a result, if a working fluid was injected into

*nandyputra@eng.ui.ac.id

that capillary tube, it will lead to the formation of liquid and vapor slugs inside [7]. Then, if a sufficient heat is applied to the evaporator sections surface then the working fluid will start to move in such random motions. The movement of working fluid will deliver the heat from the evaporator to the condenser. Oscillating Heat Pipe (OHP) is one of the recent types of heat pipe family which has found by Akachi in the earlier 1990 [1]. In addition to the high possibility at electronic cooling application, OHP also has good prospect in the heat recovery technology [2–4], solar energy [5] and many more [6].

The performance of OHP depends on several multivariate parameters such as geometry, working fluid properties, heat load, inclination angle, filling ratio, number of turns and gravitational forces [6]. Therefore, the performance of OHP is very difficult to predict with simple correlation due to many parameter influences within. A proper visualization study should be taken in order to learn more deeply about the thermo-hydrodynamics process within the OHP.

Most of the visualization study used a visible light imaging method with a transparent tube made from Quartz glass or Pyrex [7–8]. However, in reality, OHP applications use the tube from conductor material (metal). Therefore, the visualization observation using transparent tube has not provided an actual flow phenomenon inside. This is because glass and metal having the poor properties in terms of heat transfer (heat transfer coefficient and thermal conductivity). They also have a different surface roughness from metal, which obviously affects the working fluid flow. Moreover, the observation of transient temperature in glass tube will be more difficult when compared with metal tube (aluminium/copper). Thus, the thermo-hydrodynamics behavior of working fluid between glass and metal material tube clearly will have a distinction.

The visualization of OHP has been studied experimentally by several researchers, focused on either visual observation of flow patterns and various operation parameters related with thermo-hydrodynamics of OHP [7–8]. Actually, the flow patterns inside the mini-channel are quite complex to fully describe precisely. There several types of fluid movements have been shown from transparent tube visualizations literature. Among others are small oscillation, intermittent oscillatory flow, bulk oscillation, permanent oscillatory flow, circulation, and dry-out or device failure [8–11]. Also, it stated there are several flow patterns, as follows; slug flow, semi-annular flow, a combination of slug and annular flow, transition semi-annular to fully annular flow, fully annular flow and fully vaporized flow (i.e. dry-out) [9–12]. Some of the literature stated that bubbly flow as the other term of a dispersed bubble. Basically, if a bubble has a diameter much less than the inner diameter of the tube then it can be said bubbly flow or dispersed bubble [8,11]. The dispersed bubble mostly only visible with transparent tube (Glass/Pyrex) visualization experiments. However, this is the most advantage of transparent tube visualization.

Neutron radiography is a visual observation method that utilizes the penetration of radiation energy to investigate the inside part of an optically opaque object. This method is the non-destructive test, which is provided by nuclear energy technology. The application of this method at heat pipe visualization study is still very rare, therefore there is not much literature discussing the uses of this method on heat pipe visualization study.

Takenaka et al. used neutron radiography to observe the flow boiling characteristics of cryogenic fluids [13]. By utilizing the difference of significant attenuation coefficient between nitrogen as cryogenic fluid with the aluminum heat exchanger. The result is used as a reference tool for next design of the device. Asano et al. have conducted visualizing and measuring the flow of refrigerant in the capillary and distributor pipes within a compression-type refrigerator [14]. They studied two-phase flow behavior on both channels and distributors using neutron radiography visualization methods. By taking pictures at 30 fps with a CCD camera and performing image processing, the phase distribution of the heat exchangers can be well shown. Sugimoto, et al. evaluated the behavior of working fluids on a Variable Conductance Heat Pipe (VCHP) with neutron radiography [15]. Videos with 30 frames per second were taken with Electron Bombardment Charged Coupled Device (EB-CCD) camera. The visualization results reveal the benefits of mounting thin plates to inhibit fluid blockage in the heat pipe arch. Also, the effect of the working fluid filling-ratio and the absence of evaporation in the

downward inclination of heat pipe can be predicted. Using the same method, Putra et al. showed the captured image when boiling occurred inside the heat pipe with a sintered wick and wickless (thermosyphon) [16]. Borgmeyer et al. studied the capability of heat transfer and fluid flow in copper Oscillating Heat Pipe (OHP) [17]. A number of thermocouples are also placed at a number of points on the surface of the pipe wall to measure the OHP temperature distribution. Borgmeyer found that neutron radiography could help to explain the physical phenomena and two-phase flow characteristics of the working fluid in the OHP [17]. Research studies of OHP visualization using neutron imaging have been done by several researchers. Based on the literature, all the OHP material tested using copper capillary tube [17–21]. All previous researchers have also used cooling water block at condenser section, which obviously blocked the visual observation.

The aim of this study is to observe the motion of working fluid inside the OHP with radiography neutron method. For this reason, the OHP structure was built with aluminium capillary tube. The OHP experimental set was also designed to improve neutron transparency, by using airflow to conduct cooling at the condenser section. This design was set to visualize the whole part of OHP structure. In order to find the clear explanation of the real phenomenon inside the tube. The visualization and temperature data were captured at the time which synchronized before. The result of this study could provide more information about the thermo-hydrodynamic of working fluid inside the OHP.

2. Methodology

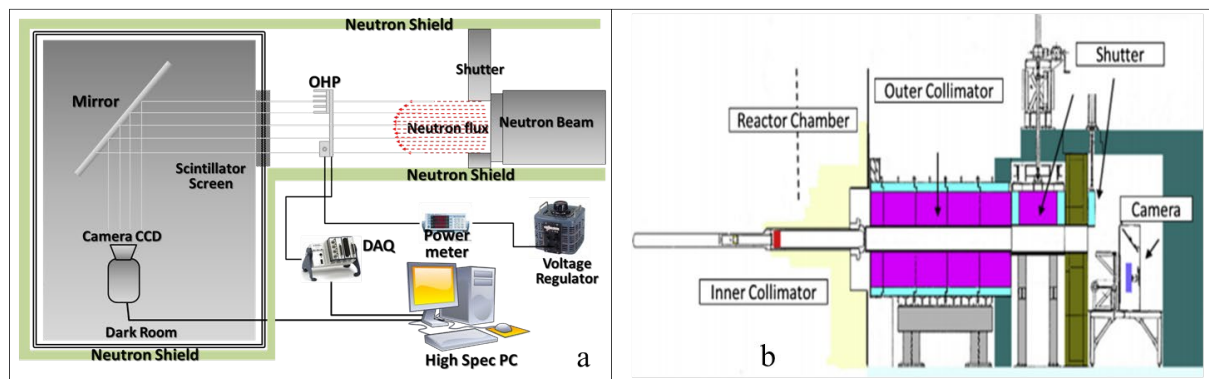

Figure 1 (a) The experimental setup of neutron radiography visualization test, (b) Neutron Radiography research facility RN1

Some explanation of this visualization method has been clearly written by Putra et al. [16]. For a simple explanation, when the object (OHP) is exposed to the beam of a neutron, each of material elements will be scattered and absorbed regard to the thickness and material properties. The Lambert-Beer law of attenuation explained the relation of neutron attenuation with property, thickness, and density of elements [18].

To perform the test, OHP was made from an aluminum capillary tube with an outer and inner diameter of 3 and 2 mm, respectively. The camera size of neutron imaging system determined the dimension OHP. Therefore, a closed loop OHP with an overall dimension of 13×14.5 cm² was design and manufactured for the visualization test (Figure 2a). A pair of a sandwich structure made from aluminum block was constructed to provide uniform heat flux at the evaporator section. It has the overall dimension of 160×20×42 mm³. The contact surface between the round shape of aluminum tube and the block was improved with the semicircular groove. In order to minimize the thermal contact between them, thermal compound (Omegaterm “201”) is used. Two cartridge heaters (Omega CSH-400) were inserted into the block through fit holes. The heater’s power was controlled by a voltage regulator and measured by a power meter. The airflow cooling for condenser was chosen to get the clear picture of flow visualization image. Heat sink with centrifugal blower was used to cool the condenser sections. Semicircular groove is machining on the backside of aluminum heat sink to

achieve better contact surface with the tube's shape. Thermal paste was used to minimize the thermal contact resistance. The wall temperatures of aluminum OHP are measured with type K thermocouples. Each of thermocouples are calibrated first before attached at OHP wall surface. The maximum error each of them was ± 0.5 °C. A data acquisition system was used to collect all the temperature data. The thermocouple positions showed at the figure 2c. All data of OHP visualization is tested at bottom heating mode. CCD Camera and data acquisition software were collected by a high specification desktop PC. The OHP was not encased in glass wool insulation to maximize the visualization result. Although this consideration setup would result in greater heat losses from the evaporator.

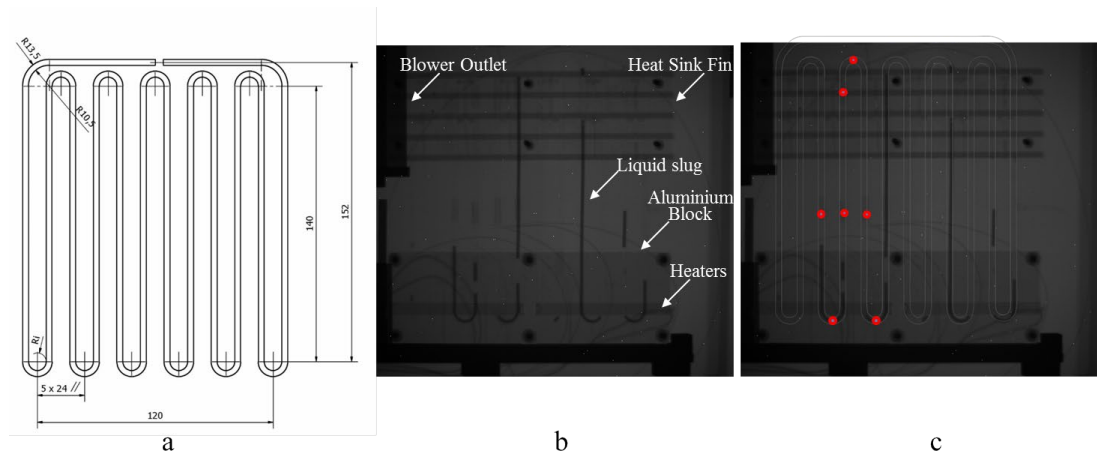

Figure 2. The OHP prototype (a) schematic of OHP, (b) Neutron radiography image of the OHP, (c) Image after marked with graphic editor software with the thermocouple positions.

Figure 1a and 1b showed the whole experimental setup of neutron radiography. The size of the OHP was dictated by the camera size of the neutron imaging system (see figure 2a). This test was conducted at neutron radiography facility, RN1, under the supervision of the Centre of Science and Technology of Advanced Materials (PSTBM), National Nuclear Energy Agency of Indonesia (BATAN). Figure 2b showed the picture of neutron radiography before the heat input is applied to the evaporator section. From the picture can be seen that the liquid slug inside the channels appeared as darkness image at the OHP loop. With Image J software, the filling ratio of OHP was confirmed at 35% (based on the ratio of liquid length and total loop of OHP). All the videos were collected at 15 fps (frame per second) rate and extracted frame by frame using video editor software. Vector graphic editor software is then used to mark the OHP structure at the extracted images from video data of visualization (figure 2c).

3. Result and Discussion

Figure 3 shows the transient temperature of evaporator, adiabatic and condenser section at OHP. Each turn of OHP numbered from left to right, to identify the channel clearly. Figure 4 shows the captured images from the start-up in time sequence. At initial condition (stage I), no heat supply was delivered to the evaporator. Stage I condition is represented very clear by figure 2b. This picture was analyzed using the image-j software to confirm the filling ratio of the OHP. After the initial condition was captured then 18 Watt of power input was supplied to the evaporator section through the cartridge heater. The evaporator's temperature then began to increase (Stage II). The captured image at second stage was showed no significant different with previous image (figure 2b). No motion of working fluid was observed at this stage. At stage III, the heat supply was increased into 40 Watt. Evaporator temperature increased more sharply than previous heat supply. However, there is no sign of working fluid movement at all. At stage IV, the heat supplied was increase to 85 Watt. Temperature evaporator still shows a sharp increase for about 200 seconds. The vapor plug may have expanded at this stage but it's hard to recognize the clearly picture. At #2 turn, the working fluid moved very fast (see figure

4) and the adiabatic temperature showed high amplitude fluctuations. The corresponding pictures of start-up showed in figure 4. The 4a and 4b frames showed the fast movement of liquid slug due to liquid evaporation at the evaporator section.

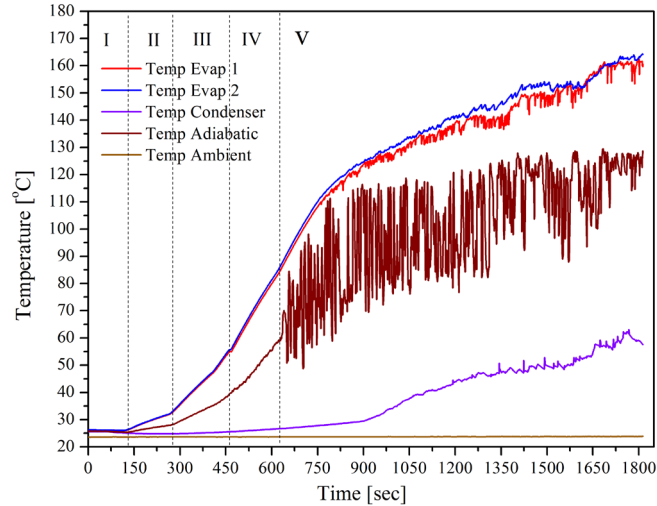

Figure 3. The transient temperature of OHP.

Figure 4a showed the sequence pictures of the instantaneous moment before the working fluid suddenly move very fast due to bubble expansion. At figure 4b, when the heat flux is high enough, the liquid slug at #2 turn was broken into two parts due to evaporation. Those two liquid slugs then quickly expelled with opposite direction. One of the liquid slug at right channel of #2 turn was merged with upper liquid slug and move together to condenser section. All liquid slugs on the channels seem moved with a different velocity. Next frames showed that only a few channels moved with significant distance (figure 4c and 4d). Interestingly, the condensation of vapor plug was observed at #2 turn left channel (figure 4c). In their report, Wilson et al. could not find this bubble collapse using the same visualization method [18].

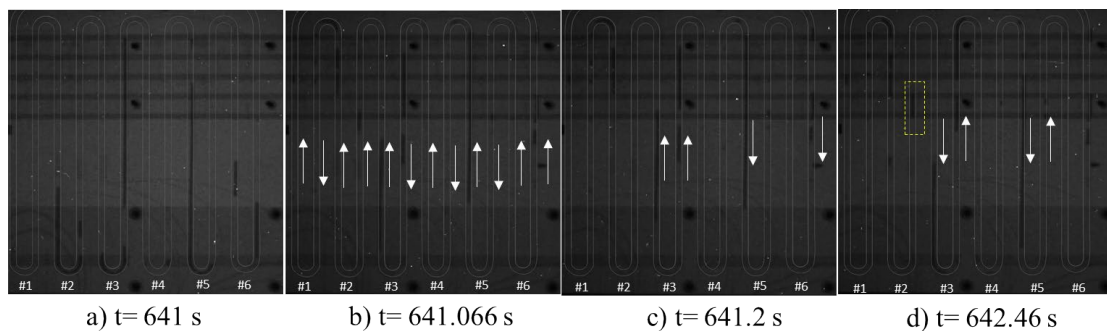

Figure 4. Fluid movement at start-up frames.

Increasing the heat load to 100 Watt (stage V) still increased the evaporator temperature. Although the adiabatic section already shows the rapid fluctuation of working fluid (figure.3). After about 770 seconds then the evaporator temperature shows the fluctuations with lower amplitude.

Unlikely with the visualization using the transparent tube, this visualization cannot observe the detail of bubble and liquid slug boundaries (figure 5a). Thus, it very difficult to measure the contact angle from the liquid meniscus. And also, the dispersed bubble and bubble growth from nucleation cannot be observed, as shown in Figure 5b and 5c. Due to the non-uniform of liquid and vapor distribution,

the velocity of fluid each of channel was extremely different (figure 5c). The liquid at #5 turn evaporated and then expelled the remaining slug with high velocity which results to blur frame pictures. However the right channel of #6 turn show only little movement of liquid slug. Blurring images happened when the velocity of the liquid slug was higher enough to capture by only 15 fps of video camera adjustment. Even though the picture of moving liquid slug at evaporation sections was still blur due to inadequate of fps video. But more realistic phenomena could be observed from the related image and temperature data.

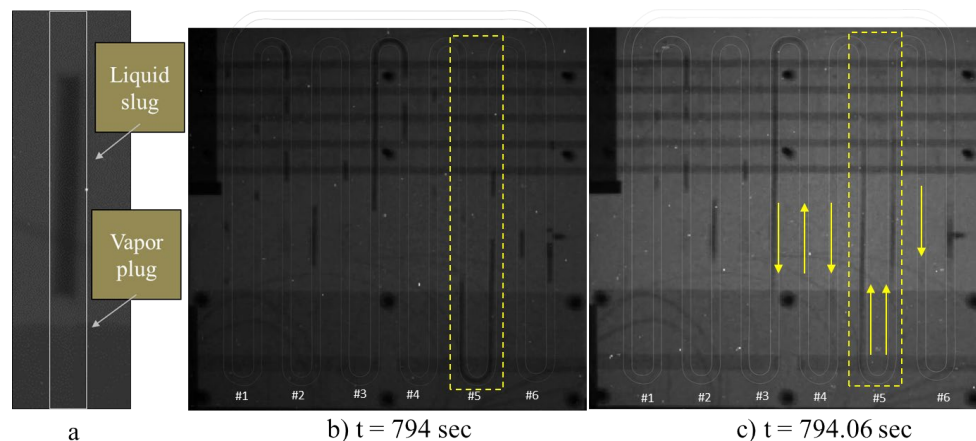

Figure 5. (a) Liquid slug and vapour plugs, (b) Instantaneous frames before evaporation, (c) After evaporation

From the fluid images and temperatures data, it can be confirmed that the fluctuations temperature at the adiabatic and evaporator were occurred due to the motion of liquid slug and vapor plug. If the slug was passing the thermocouple surface point then the significant temperature drop will occurs at adiabatic sections. The temperature increased occurs when hot slug pass the point measurement surface again. The up and down motions of liquid slug caused temperature fluctuations in the adiabatic section (see figure 3). These results seem contradicted with already reported by Xu et al [22]. In summary, the temperature data coupled with related fluid flow movements will provide a better approach to thermo-hydrodynamic behaviour analysis in oscillating heat pipe.

4. Conclusion

Preliminary study on visualization fluid flow through neutron radiography has been conducted with aluminium OHP. From the resulted images, the motions of fluid flow within the capillary tube could observe well. The collapsing of vapor bubble was observed at condenser section. The evaporation of liquid slug was captured adequately also. The detailed bubble information, like nucleation, dispersed bubble growth and contact angle of the bubble meniscus could not observe clearly due to the small dimension of the OHP tube. Higher diameter tube with appropriate working fluid may solve this problem. The temperature data and fluid flow pictures could explain more accurate about the thermo-hydrodynamic of the working fluid. The fluctuations of the transient temperature at evaporator and adiabatic are one of the cases which could be explained well by this visualization method. The higher quality of video capture should be taken in the next study to maximize the quality of pictures. Thus, the deeply analysed could have been done from the result data.

Acknowledgment

The authors would like to thank DRPM Universitas Indonesia for funding this research through PUPT research scheme.

Reference

- [1] Akachi H 1990 Structure of heat pipe. US Patent 4, 921, 041

- [2] Meena P, Rittidech S and Poomsa-Ad N 2007 Application of close-loop oscillating heat-pipe with check valves (CLOHP/CV) air preheater for reduced relative-humidity in drying systems *J. Appl. Ener.* **84** 553
- [3] Rittidech S, Dangeton W and Soponronnarit S 2005 Close-ended oscillating heat pipe (CEOHP) air-preheater for energy thrift in a dryer *J. Appl. Ener.* **81** 198
- [4] Winarta A, Putra N and Bakhtiar F 2017 Thermal performance of oscillating heat pipe with ethanol/methanol for heat recovery application design *J. Ijaseit* **7** 1268
- [5] Kargarsharifabad H, Mamouri S.J, Shafii M and Rahni M.T 2013 Experimental investigation of the effect of using closed-loop pulsating heat pipe on the performance of a flat plate solar collector *J. Ren. Sust. Ener.* **5** 013106
- [6] Han X, Wang X, Zheng H, Xu X and Chen G 2016 Review of the development of pulsating heat pipe for heat dissipation *J. Ren. And Sust. Ener. Rev* **59** 692
- [7] Tong BY, Wong T and Choi K 2001 Closed-loop pulsating heat pipe *J. ATE.* **21** 1845
- [8] Xu J, Li Y and Wong T 2005 High speed flow visualization of a closed loop pulsating heat pipe *J. Int. J. Heat and Mass Trf.* **48** 3338
- [9] Karthikeyan V, Ramachandran K, Pillai B and Solomon A.B 2015 Understanding thermo-fluidic characteristics of a glass tube closed loop pulsating heat pipe: flow patterns and fluid oscillations *J. Heat and Mass Trf.* **51** 1669
- [10] Khandekar S, Charoensawan M, Groll M and Terdtoon 2003 Closed loop pulsating heat pipes Part B: visualization and semi-empirical modelling *J. ATE* **23** 2021
- [11] Goshayeshi H.R, Chaer I 2016 Experimental study and flow visualization of Fe₂O₃/kerosene in glass oscillating heat pipes, *J. ATE* **103** 1213
- [12] Li QM, Zou J, Yang Z, Duan YY, Wang BX 2011 Visualization of two-phase flows in nanofluid oscillating heat pipes *J. Heat Trf.* **133** 052901
- [13] Takenaka N, Fujii T, Akagawa K, Ono A, Sonoda K, Nishizaki K, Asano H. 1990 Application of neutron radiography to visualization of multiphase flows *J. Flow and Instr.* **1** 149
- [14] Asano H, Takenaka N, Fujii T, Shibata Y, Ebisu T, Matsubayashi M. 1999 Visualization and measurement of refrigerant flow in compression-type refrigerator by neutron radiography *J.N.Ins.Meth.in Phy.Res. Sec. A* **424** 98
- [15] Sugimoto K, Asano H, Murakawa H, Takenaka N, Nagayasu T, Ipposhi S. 2011 Evaluation of liquid behavior in a Variable Conductance Heat Pipe by neutron radiography *J.N.Ins.Meth.in Phy.Res. Sec. A* **651** 264
- [16] Putra N, Ramadhan RS, Septiadi WN 2015 Visualization of the boiling phenomenon inside a heat pipe using neutron radiography *J. ETFS* **66** 13
- [17] Borgmeyer B, Wilson C, Winholtz RA, Ma HB, Jacobson D, Hussey D 2010 Heat transport capability and fluid flow neutron radiography of three-dimensional oscillating heat pipes *J. Heat Trf.* **132** 061502
- [18] Wilson C, Borgmeyer B, Winholtz RA, Ma HB, Jacobson DL, Hussey DS, Arif M. 2008 Visual observation of oscillating heat pipes using neutron radiography *J. Therm. and H Trf.* **22** 366
- [19] Wilson C, Borgmeyer B, Winholtz RA, Ma HB, Jacobson D, Hussey D. 2011 Thermal and visual observation of water and acetone oscillating heat pipes *J. H. Trf.* **133** 061502
- [20] Thompson SM, Ma HB, Wilson C. 2011 Investigation of a flat-plate oscillating heat pipe with Tesla-type check valves *J. ETFS* **35** 1265
- [21] Monroe JG, Thompson SM, Aspin ZS, Jacobson DL, Hussey DS. 2014 Neutron Imaging of an Unbalanced Flat-Plate Oscillating Heat Pipe *In 52nd AIAA SciTec*
- [22] Xu JL, Zhang XM 2005 Start-up and steady thermal oscillation of a pulsating heat pipe *J. H M Trf.* **41** 685