

# Thermal performance of Pulsating Heat Pipe on Electric Motor as Cooling Application

*by* Adi Winarta

---

**Submission date:** 07-May-2023 10:01AM (UTC+0700)

**Submission ID:** 2086196875

**File name:** 4\_e3sconf\_i-trec2018\_03035.pdf (640.78K)

**Word count:** 3275

**Character count:** 17469

## 10 Thermal performance of Pulsating Heat Pipe on Electric Motor as Cooling Application

Nurhalimah Aprianingsih<sup>1</sup>, Adi Winarta<sup>1</sup>, Bambang Ariantara<sup>1,2</sup>, Nandy Putra<sup>1\*</sup>

<sup>1</sup>Applied Heat Transfer Research Group, Department of Mechanical Engineering<sup>1,2</sup>, Faculty of Engineering, Universitas Indonesia, Kampus Baru-Depok, Jawa Barat, 16424

<sup>2</sup>Mechanical Engineering Department, Faculty of Engineering, Universitas Pasundan, Jl. Setiabudi No. 193 Bandung 40153

<sup>32</sup>\*Corresponding Author: [nandyputra@eng.ui.ac.id](mailto:nandyputra@eng.ui.ac.id)

**Abstract.** Heat generated in an electric motor can increase the operating temperature. The excessive operating temperature will reduce the electric motor performance and shorten the service life. An appropriate thermal management system is required to reduce the electric motor operating temperature. The objective of this study is to determine the thermal performance of pulsating heat pipes which applied to the electric motor thermal management system. A prototype of electric motor thermal management system was made from an induction motor with a cartridge heater instead of a heat-generating rotor and stator. Six pieces of pulsating heat pipe were mounted using hexagonal heat pipe holder which placed inside the electric motor housing. The pulsating heat pipes are made of a copper capillary tube using acetone as working fluid with a filling ratio of 0.5. The electric power input was varied from 30 W to 150 W. The use of pulsating heat pipes can reduce the electric motor surface temperature by 55.3°C with the minimum thermal resistance of 0.151 °C/W.

### 1. Introduction

<sup>27</sup>The flow of electric current through stator and rotor of an electric motor, in the process of energy conversion, will increase the working temperature. Electric motors will work optimally at a certain working temperature. If they operate at excessive working temperature, their performance will be reduced due to Joule losses which can be expressed as  $I^2R$ , where I and R represent electric current and electric resistance respectively [1]. Also, the excessive working temperature will shorten the motor service life.

In general, electric motors used fins and an axial fan as tools of the thermal management system to reduce electric motor's working temperature. The fins are usually mounted on an electric motor outer surface, which is its housing. Its function is to increase heat transfer rate by natural convection. The fans are used to increase heat transfer rate by forced convection. Many studies have been conducted to find another

method to increase cooling performance of the electric motor.

Farsane et al. [2] have been conducted about measuring cooling temperatures on cooling closed-circuit electric motors by fins and fans. Li [3] put forward modification on electric motor's design of permanent magnet electric motors with a centrifugal impeller with aim improving electric motor cooling performance. Davin [4] carried out an experimental study of lubricating oil used as electric motors' coolant. In a high operation, electric motors resulting in high heat, a method of flowing coolant through jacket placed between the stator may release heat to ambient air more effectively.

<sup>1</sup>A heat pipe is a compact, light and passive thermal device with a quite low thermal resistance [5]. The study on heat pipe used in electronic devices as a tool of thermal management system has been conducted by Putra et al. [6-8], Weng et al. [9], and Wang [10].

Using heat pipe on electric vehicle batteries as thermal management system has also been carried out [11]. Putra et al. [12] introduced a thermal management system of electric motors using L-shaped flat heat pipes attached to the surface of the motor housing. The results show a significant decrease in temperature on the electric motor casing.

Akachi [13] was first proposed pulsating or oscillating heat pipe in 1990. Pulsating heat pipe proved to be a simple, reliable, noiseless tool and an economical choice for heat transfer device. It's because of it has many advantages [14-16]: (1) simple structure and low cost: PHP is made of the capillary tube which can be bent as needed. (2) excellent heat transfer capabilities: according to Shang et al. [17]. (3) Easy to miniaturization: it is one of the most exciting characteristics of PHP. The size of PHP can be so small because of its inner diameter either could be so small; and (4) high flexibility: PHP channels can be arranged for the various arrangement according to the situation of the application.

The objective of this study is to determine the performance of thermal management system of an electric motor using pulsating heat pipes experimentally.

## 2. Methodology

### 2.1 Pulsating Heat Pipe

Pulsating heat pipe which was used in this study were made from a copper tube with 3.1 and 1.6 mm for outer and inner diameter, respectively. Copper has many properties, two main properties which beneficial for pulsating heat pipe are the thermal conductance of copper was very high and good malleability for constructing the serpentine design. The tube diameter was chosen based on the limited sizes available and meets the dimension constraint of Eq. (1) suggested by Akachi et al. [18] for critical diameter.

$$D_{crit} = Bo \sqrt{\frac{\sigma}{g(\rho_1 - \rho_v)}} \quad (1)$$

Bond number ( $Bo$ ) has been used for numerous studies to determine the critical diameter of the tube. Each classification states for surface tension, channel size, and fluid density effects on flow within these devices. Some studies have referenced a  $Bo$  value of 1.84 [19, 20], others have a value of 2 used for diameter calculations [18, 21-23] while others examined a range of  $Bo$  numbers [24]. This study used a  $Bo$  of 2, as Akachi et al. [18] primarily suggested.

Calculations were made for each two working fluid tested and for various temperatures since the PHP was exposed to a range from ambient to 120°C. The calculation resulted in smallest critical diameter for all conditions was found to be 2.59 mm, which is still larger than the 1.6 mm inner diameter of the copper tube used.

**Table 1** PHP minimum and maximum diameters.

Working fluid	$D_{min}$ , mm	$D_{max}$ , mm	$D_{max} \mu g$ , mm
Water	1.90	4.98	28.77
Acetone	1.21	3.17	11.66
Ammonia	1.28	3.36	12.98
R-134a	0.56	1.52	2.61
HFO-1234yf	0.53	1.40	2.18

The working fluid used in this study is acetone. In Table 1, it seems that that acetone meets the capillary pipe diameter criteria used. Acetone has a low boiling point, which is 56.53°C at atmospheric pressure. The lower the boiling point of a working fluid, the resulting latent heat is also lower. Lower latent heat will be useful for forming and breaking bubbles faster, as well as shortening the starts up time in PHP. When the latent heat of the working fluid is low, the lower superheat in the pipe wall can be started in PHP [23].

The charge ratio, the ratio of working fluid volume to total volume of the PHP, has a significant influence on the PHP performance because of the fact that the relative amounts of liquid plugs and vapor slugs depend on the charge ratio. The pulsating heat pipe can operate normally with a charge ratio between 0.2 and 0.8, showed by experimental studies [25, 26].

### 2.2 Electric Motor Prototype

The study was conducted using a conventional electric motor. It modified in such a way as to simulate the heat transfer in an electric motor by using a cartridge heater. The rotor is replaced with cartridge heater with a diameter of 12.5 mm and a length of 8 mm. The stator or magnetic winding component is replaced by a 6-sided prism that forms a hexagonal heat pipe mounting. The outside surface of the hexagonal heat pipe mounting forms a cylindrical surface that matched the inside surface of the motor housing. The ready-to-use pulsating heat pipe is then mounted on each side of the 6-sided prism.

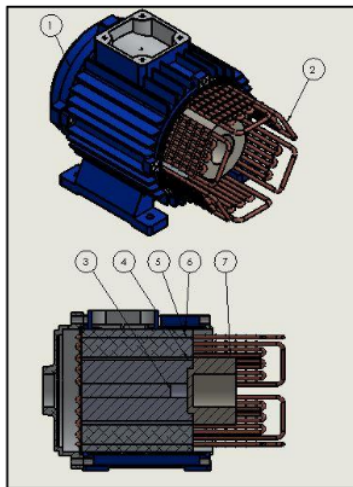

- 1 Electric motor housing
- 2 Pulsating heat pipe
- 3 Cartridge heater
- 4 Cylinder cartridge heater mounting
- 5 Hexagonal mounting
- 6 Pulsating heat pipe upper mounting
- 7 Isolator

24  
**Figure 1. Electric motor prototype with pulsating heat pipe.**

The pulsating heat pipe is inserted on each side of the hexagonal mounting with the evaporator side positioned near the cartridge heater, while the condenser side is positioned outside the motor housing. The evaporator absorbs the heat generated by the cartridge heater and transported to the condenser. An axial fan is used to increase the convection heat transfer rate from the condenser side to the ambient air. The design of electric motor prototype and its components is shown in **Figure 1**.

The temperature measuring instrument used in this research is 0.3 mm K-type thermocouples. Thermocouples are installed at several points on the electric motor simulator. Placement of the thermocouple is arranged to obtain the temperature distribution on the electric motor on the inside and outside of the electric motor. The inner thermocouples are placed on a twelve-point of cartridge heater mounting, six points on one side, and six on the other. While the outer thermocouples placed on the electric motor casing that amounted to twelve points. The installation of each thermocouple on the motor housing is aligned with the inside thermocouple point. The arrangement is made to determine the radial temperature distribution from the cartridge heater to the motor shroud. The thermocouple installation

illustration for the temperature distribution is shown in **Figure 2**.

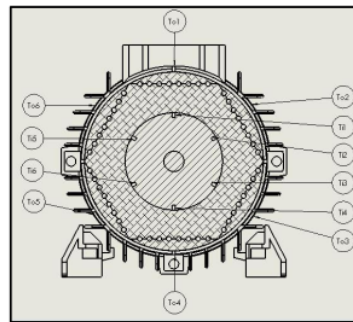

**Figure 2. Thermocouple placement.**

Thermocouples are also placed on each PHP. The thermocouples are attached to each pulsating heat pipe, one on the evaporator side and one on the condenser side. Each of the thermocouples paired to the same one pulsating heat pipe should be aligned to know the temperature distribution at pulsating heat pipe. Based on the temperature data, the value of thermal resistance of each pulsating heat pipe can be obtained. The thermocouples are connected to a National Instrument Data Acquisition system.

### 2.3 Experimental Schematic

The experimental setup in this study is depicted in **Figure 3**. An AC voltage regulator is used to adjust the input power to the cartridge heater. The electric voltage, electric current, and electric power are measured using a digital power meter. All thermocouple is connected to a National Instrument Data Acquisition system.

For every single variation of working fluid and orientation, heat loads of 30, 60, 90, 120 and 150 W were applied. Experiments were carried out in the laboratory at ambient temperatures of 26-30°C. The experiments started with a 30Watt heat load. The heating is applied until the steady state is reached. About twenty minutes after the steady state was reached, the heat load is increased to 60 W. This procedure is repeated at a heat load of 90 W, 120 W, and 150 W. The similar experiments were conducted without using pulsating heat pipes.

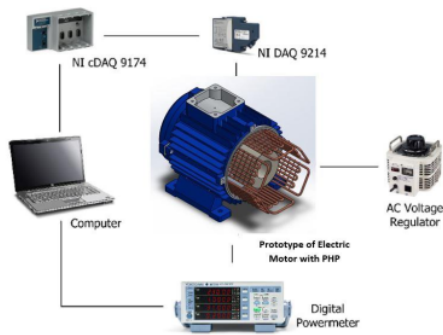

Figure 3. Schematic of experimental setup.

### 3. Results and Discussion

#### 3.1. Temperature and Heat Load Measurement

Figure 4 shows the results of the temperature and measurement for ever heat load. The heat load fluctuation is increased rapidly with the voltage because the heater is a quadratic function of the voltage. The inner surface temperature of the cylinder shows little differences; this is due to the non-uniform heat propagation due to the difference in length,  $x$ , from the cartridge heater to the cylinder. While the external surface temperature shows a significant difference due to the placement of one thermocouple adjacent to the axial fan, resulting in lower temperature.

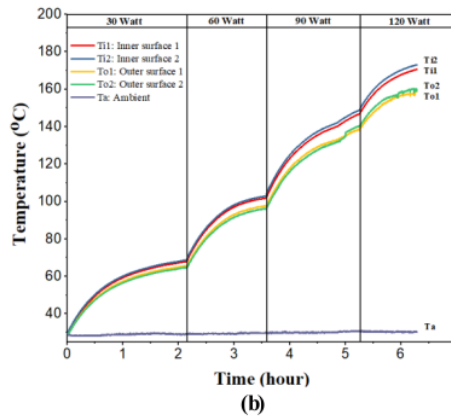
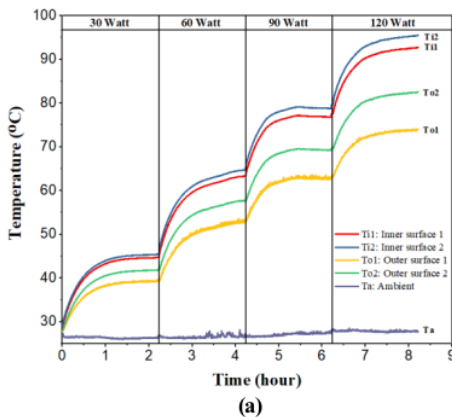

Figure 4. Temperature and heat load measurement; (a) With PHP and (b) Without PHP.

Temperature measurements without PHP are carried out by measuring the temperature on a PHP's mounting; this is to facilitate the retrieval of data. Then to know the external surface temperature of the electric motor, used theoretical approach, as follows.

Calculation of the rate of conduction of electric motor heat transfer from cartridge heater to hexagonal mounting using heat rate equation on Eq. (2) and (3), suggested by Bregman et al. [27] as follows,

$$Q = kA \frac{dT}{dx} \quad (2)$$

#### Calculation of outer surface temperature of the electric motor

Using heat rate equation for the cylinder,

$$Q = \frac{2\pi Lk\Delta T}{\ln(r_2/r_1)} \quad (3)$$

with  $L = 0.1 \text{ m}$ ;  $r_1 = 0.0475 \text{ m}$ ; and  $r_2 = 0.0548 \text{ m}$ .

#### 3.2. Steady state temperature versus heat load

Determination of steady state temperatures is by averaging the value of temperature over the last twenty minutes during the steady state period. The steady temperatures at each heat load on the inner and outer surfaces of the electric motor with PHP result in Figure 5. The result shows that steady temperatures of the electric motor increase with the increasing heat loads; this corresponds to the theory that the greater the heat loads, then the greater the temperature difference shown in the equation of the heating rate.

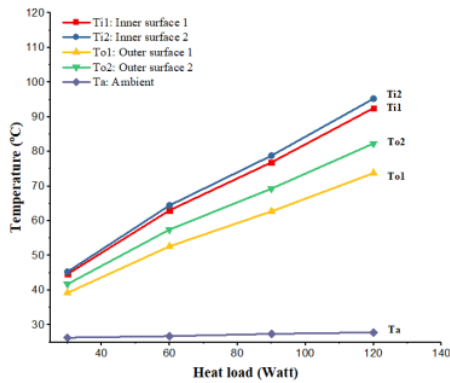

**Figure 5.** Steady state temperature vs. heat load.

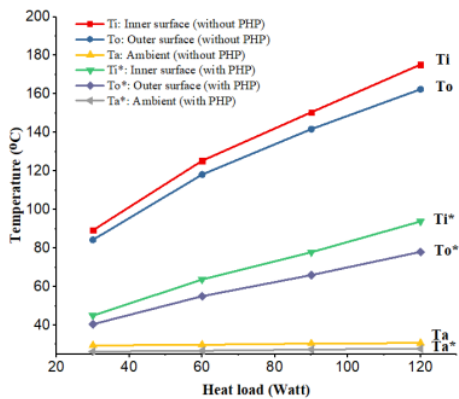

**Figure 6.** Electric motor working temperature with and without PHP.

The comparison between using and without pulsating heat pipe of the inner and outer surface of electric motor shows in **Figure 6**. Implementation of pulsating heat pipe in the electric motor thermal effects its thermal management system. The temperature of the inner and outer surface of the cylinder increases with the heat load. The electric motor without using pulsating heat pipe, the temperature reach 175.25°C and 162.11°C. While the use of the PHP reduces the temperature of 93.90°C and 78.06°C, or a reduction by 81.35°C and 84.05°C, for the inner and outer surface of the cylinder respectively at the heat load of 120W.

#### 4. Thermal Resistance

The thermal performance of a PHP is calculated based on the time-averaged evaporator and condenser temperature as per Eqs. (4) and (5). Total heat supplied is calculated through Eq. (6) and thermal resistance is calculated through Eq. (7). The equations is suggested by [28]. The heat is fullt dissipated along the pulsating heat pipe so that  $Q_{loss}$  can be negligible.

$$\text{Average evaporator temperature, } T_e = \frac{1}{5} \sum_{i=1}^5 T_i \quad (4)$$

$$\text{Average condenser temperature, } T_c = \frac{1}{5} \sum_{i=1}^5 T_i \quad (5)$$

$$\text{Total heat supply, } Q = VI \quad (6)$$

$$\text{Thermal resistance, } R = \frac{T_e - T_c}{Q - Q_{loss}} \quad (7)$$

Based on **Figure 7** thermal resistance increases with the increasing heat loads. This is in accordance with the theory of heat transfer rate where the value of the heat rate,  $Q$ , is inversely proportional to the thermal resistance,  $R$ . As a result, the thermal resistance at heat load above 60W decreasing sharply, which means the performance of pulsating heat pipe is better when it reached heat load up to 60W.

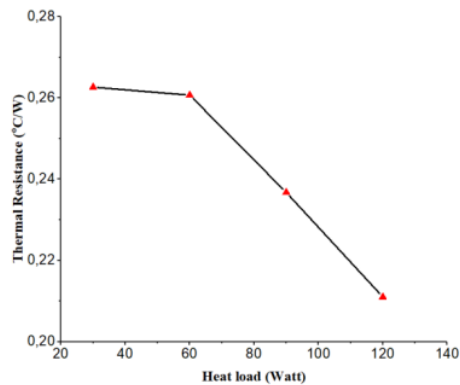

**Figure 7.** The thermal resistance of PHP.

#### 5. Conclusions

The experiments to make the prototype and to determine the performance of electric motor thermal management system using pulsating heat pipe have been successfully conducted. The temperature of the outer surface of the electric motors decreased by 84.05°C, or from 162.11°C to 78.06°C, with a thermal resistance of 0.21°C/W, at heat load 120W. The best pulsating heat pipe's performance shows at heat load above 60W.

#### Acknowledgement

The authors would like to thank the DRPM (Directorate of Research and Community Service), Universitas Indonesia for funding this research through PITTA Scheme.

#### References

1. Huai, Y., R.V. Melnik, and P.B. Thogersen, *Computational analysis of temperature rise phenomena in electric induction motors*. Applied Thermal Engineering, 2003. **23**(7): p. 779-795.
2. Farsane, K., P. Desevaux, and P. Panday, *Experimental study of the cooling of a closed type electric motor*. Applied Thermal Engineering, 2000. **20**(14): p. 1321-1334.
3. Li, H., *Cooling of a permanent magnet electric motor with a centrifugal impeller*. International journal of heat and mass transfer, 2010. **53**(4): p. 797-810.
4. Davin, T., et al., *Experimental study of oil cooling systems for electric motors*. Applied Thermal Engineering, 2015. **75**: p. 1-13.
5. Chaudhry, H.N., B.R. Hughes, and S.A. Ghani, *A review of heat pipe systems for heat recovery and renewable energy applications*. Renewable and Sustainable Energy Reviews, 2012. **16**(4): p. 2249-2259.
6. Putra, N. and F.N. Iskandar, *Application of nanofluids to a heat pipe liquid-block and the thermoelectric cooling of electronic equipment*. Experimental Thermal and Fluid Science, 2011. **35**(7): p. 1274-1281.
7. Putra, N. and W.N. Septiadi, *Improvement of heat pipe performance through integration of a coral biomaterial wick structure into the heat pipe of a CPU cooling system*. Heat and Mass Transfer, 2017. **53**(4): p. 1163-1174.
8. Putra, N., et al. *Application of Al<sub>2</sub>O<sub>3</sub> nanofluid on sintered copper-powder vapor chamber for electronic cooling*. in *Advanced Materials Research*. 2013. Trans Tech Publ.
9. Weng, Y.-C., et al., *Heat pipe with PCM for electronic cooling*. Applied Energy, 2011. **88**(5): p. 1825-1833.
10. Wang, J.-C., *L-type heat pipes application in electronic cooling system*. International Journal of Thermal Sciences, 2011. **50**(1): p. 97-105.
11. Putra, N., B. Ariantara, and R.A. Pamungkas, *Experimental investigation on performance of lithium-ion battery thermal management system using flat plate loop heat pipe for electric vehicle application*. Applied Thermal Engineering, 2016. **99**: p. 784-789.
12. Putra, N. and B. Ariantara, *Electric motor thermal management system using L-shaped flat heat pipes*. Applied Thermal Engineering, 2017. **126**: p. 1156-1163.
13. Akachi, H., *Structure of a heat pipe*. 1990, Google Patents.
14. Groll, M. and S. Khandekar, *Pulsating heat pipes: progress and prospects*. in *Proceedings of the International Conference on Energy and the Environment, China*. 2003.
15. Khandekar, S., et al. *Closed and open loop pulsating heat pipes*. in *K-4, Proceedings of 13th International Heat Pipe Conference, China Academy of Space Technology, Shanghai, China*. 2004.
16. Khandekar, S., M. Schneider, and M. Groll, *Mathematical modeling of pulsating heat pipes: state of the art and future challenges*. Heat and Mass Transfer, SK Saha, SP Venkateshen, BVSSS Prasad, and SS Sadhal, eds., Tata McGraw-Hill Publishing Company, New Delhi, India, 2002: p. 856-862.
17. Shang, F., et al., *Experimental investigation of enhanced heat transfer of self-exciting mode oscillating-flow heat pipe with non-uniform profile under laser heating*. WIT Transaction on Engineering Sciences: Advanced Computational Methods In Heat Transfer IX, Southampton, UK, 2006: p. 241-248.
18. Akachi, H., *Pulsating heat pipes*. Proc. 5<sup>th</sup> IHPS, Nov.(1996), 1996: p. 208-217.
19. Borgmeyer, B., et al., *Heat transport capability and fluid flow neutron radiography of three-dimensional oscillating heat pipes*. Journal of Heat Transfer, 2010. **132**(6): p. 061502.
20. Ma, H., et al., *Effect of nanofluid on the heat transport capability in an oscillating heat pipe*. Applied Physics Letters, 2006. **88**(14): p. 143116.
21. Khandekar, S., et al., *Thermofluid dynamic study of flat-plate closed-loop pulsating heat pipes*. Micro scale thermophysical engineering, 2002. **6**(4): p. 303-317.
22. Riehl, R.R., *Characteristics of an open loop pulsating heat pipe*. 2004, SAE Technical Paper.
23. Zhang, Y. and A. Faghri, *Advances and unsolved issues in pulsating heat pipes*. Heat Transfer Engineering, 2008. **29**(1): p. 20-44.
24. Rittidech, S., N. Pipatpaiboon, and P. Terdtoon, *Heat-transfer characteristics of a closed-loop oscillating heat-pipe with check valves*. Applied energy, 2007. **84**(5): p. 565-577.
25. Shafii, M.B., A. Faghri, and Y. Zhang, *Thermal modeling of unlooped and looped pulsating heat pipes*. Journal of heat transfer, 2001. **123**(6): p. 1159-1172.
26. Vassilev, M., et al. *Experimental study of a pulsating heat pipe with combined circular and square section channels*. in *Industry Applications Conference, 2007. 42nd IAS Annual Meeting. Conference Record of the 2007 IEEE*. 2007. IEEE.
27. Bergman, T.L., et al., *Fundamentals of heat and mass transfer*. 2011: John Wiley & Sons.
28. Xue, Z. and W. Qu, *Experimental study on effect of Inclination angles to Ammonia pulsating heat pipe*. Chinese Journal of Aeronautics, 2014. **27**(5): p. 1122-1127.

# Thermal performance of Pulsating Heat Pipe on Electric Motor as Cooling Application

## ORIGINALITY REPORT

19%

SIMILARITY INDEX

12%

INTERNET SOURCES

15%

PUBLICATIONS

5%

STUDENT PAPERS

## PRIMARY SOURCES

- 1** Bambang Ariantara, Nandy Putra, Sugeng Supriadi. "Battery thermal management system using loop heat pipe with LTP copper capillary wick", IOP Conference Series: Earth and Environmental Science, 2018  
Publication 2%
- 2** [etd.adm.unipi.it](http://etd.adm.unipi.it)  
Internet Source 2%
- 3** Patel, Vipul M., Gaurav, and Hemantkumar B. Mehta. "Influence of working fluids on startup mechanism and thermal performance of a closed loop pulsating heat pipe", Applied Thermal Engineering, 2017.  
Publication 1%
- 4** [pdfs.semanticscholar.org](http://pdfs.semanticscholar.org)  
Internet Source 1%
- 5** Mithun Sundar S, Swathi S, Kailash S. Prem, Chithrakumar V. K. "Thermal management system based on closed-loop pulsating heat 1%



# pipe for electric motors", Heat and Mass Transfer, 2021

Publication

---

6	Nandy Putra, Adjie Fahrizal Sandi, Bambang Ariantara, Nasruddin Abdullah, Teuku Meurah Indra Mahlia. "Performance of beeswax phase change material (PCM) and heat pipe as passive battery cooling system for electric vehicles", Case Studies in Thermal Engineering, 2020 Publication	1 %
7	laris.univ-angers.fr Internet Source	1 %
8	www.indusedu.org Internet Source	1 %
9	Iwan Setyawan, Nandy Putra, Imansyah Ibnu Hakim. "Experimental investigation of the operating characteristics of a hybrid loop heat pipe using pump assistance", Applied Thermal Engineering, 2018 Publication	1 %
10	www.semanticscholar.org Internet Source	1 %
11	Submitted to University of Northumbria at Newcastle Student Paper	<1 %

---

12

Internet Source

&lt;1 %

13

[nottingham-repository.worktribe.com](https://nottingham-repository.worktribe.com)

Internet Source

&lt;1 %

14

Artem Sokolov. "A note on the variance of rank-based selection strategies for genetic algorithms and genetic programming", Genetic Programming and Evolvable Machines, 08/12/2007

Publication

&lt;1 %

15

Brent S. Taft, Andrew D. Williams, Bruce L. Drolen. "Review of Pulsating Heat Pipe Working Fluid Selection", Journal of Thermophysics and Heat Transfer, 2012

Publication

&lt;1 %

16

Jingru Zhan, Xi Chen, Yuzhe Ji, Pu Zheng, Wenhui Duan. "Experimental study of ethane pulsating heat pipe with varying evaporator lengths based on pulse tube refrigerator", International Journal of Refrigeration, 2022

Publication

&lt;1 %

17

P. Meena, S. Rittidech. "Comparisons of Heat Transfer Performance of a Closed-looped Oscillating Heat Pipe and Closed-looped Oscillating Heat Pipe with Check Valves Heat Exchangers", American Journal of Engineering and Applied Sciences, 2008

Publication

&lt;1 %

---

18	<a href="http://mospace.umssystem.edu">mospace.umssystem.edu</a> Internet Source	<1 %
19	<a href="http://pure.coventry.ac.uk">pure.coventry.ac.uk</a> Internet Source	<1 %
20	<a href="http://www.sciencegate.app">www.sciencegate.app</a> Internet Source	<1 %
21	Hongwei Li, Jian Ren, Dandan Yin, Guolong Lu, Changhe Du, Xu Jin, Yuting Jia. "Effects of inclination angle and heat power on heat transfer behavior of flat heat pipe with bionic grading microchannels", Applied Thermal Engineering, 2022 Publication	<1 %
22	Kods Grissa, Adel M. Benselama, Zied Lataoui, Cyril Romestant, Yves Bertin, Abdelmajid Jemni. "Performance of a cylindrical wicked heat pipe used in solar collectors: Numerical approach with Lattice Boltzmann method", Energy Conversion and Management, 2017 Publication	<1 %
23	Stephen Manova, Lazarus Godson Asirvatham, Jefferson Raja Bose, Trijo Tharayil, Somchai Wongwises. "Effect of confluence length on the heat transport capability of ultra-thin multiport minichannel thermosyphon", Applied Thermal Engineering, 2022	<1 %

---

---

24	<a href="http://aisberg.unibg.it">aisberg.unibg.it</a> Internet Source	<1 %
25	<a href="http://hdl.handle.net">hdl.handle.net</a> Internet Source	<1 %
26	<a href="http://openprairie.sdstate.edu">openprairie.sdstate.edu</a> Internet Source	<1 %
27	<a href="http://tel.archives-ouvertes.fr">tel.archives-ouvertes.fr</a> Internet Source	<1 %
28	<a href="http://tudr.thapar.edu:8080">tudr.thapar.edu:8080</a> Internet Source	<1 %
29	<a href="http://www.akademiabaru.com">www.akademiabaru.com</a> Internet Source	<1 %
30	Chenxi Li, Ji Li. "Passive Cooling Solutions for High Power Server CPUs with Pulsating Heat Pipe Technology: Review", <i>Frontiers in Energy Research</i> , 2021 Publication	<1 %
31	E. Sedighi, A. Amarloo, M.B. Shafii. "Experimental investigation of the thermal characteristics of single-turn pulsating heat pipes with an extra branch", <i>International Journal of Thermal Sciences</i> , 2018 Publication	<1 %
32	<a href="http://serisc.org">serisc.org</a> Internet Source	<1 %

---

33

Dang, Chao, Li Jia, and Qianyi Lu.  
"Investigation on thermal design of a rack  
with the pulsating heat pipe for cooling CPUs",  
Applied Thermal Engineering, 2017.

Publication

---

<1 %

34

Junkui (, N.A. Allen), N.A. Huang, Shervin Shoai  
Naini, Richard Miller, Denise Rizzo, Katie  
Sebeck, John Wagner. "Unmanned  
autonomous ground hybrid vehicle thermal  
management system: design and control",  
International Journal of Vehicle Performance,  
2020

Publication

---

<1 %

---

Exclude quotes      On

Exclude matches      Off

Exclude bibliography      On

# Thermal performance of Pulsating Heat Pipe on Electric Motor as Cooling Application

---

GRADEMARK REPORT

---

FINAL GRADE

**/0**

GENERAL COMMENTS

**Instructor**

---

PAGE 1

---

PAGE 2

---

PAGE 3

---

PAGE 4

---

PAGE 5

---

PAGE 6

---