

Paper_19_PI_INSuamir_2015

by I Nyoman Suamir

Submission date: 11-May-2023 08:26AM (UTC+1000)

Submission ID: 2089855780

File name: Paper_19_PI_INSuamir_2015.pdf (334.62K)

Word count: 4509

Character count: 23722

INTEGRATION OF HEAT PUMP AND HEAT RECOVERY OF CENTRAL AC SYSTEM FOR ENERGY USE REDUCTION OF HOTEL INDUSTRY

23
I Nyoman SUAMIR^(*), I Nengah ARDITA^(*), Nyoman Indah Kusuma DEWI^(**)
^(*)Mechanical Engineering Department, ^(**)Department of Business Administration,
Bali State Polytechnic, Bali, 80364, Indonesia
*E-mail address: nyomansuamir@pnb.ac.id

ABSTRACT

This paper studied integration of heat pump and air conditioning systems to provide heating for hot water as well as cooling for hotel services based on weather conditions and energy costs in Indonesia. The paper also analyzed environmental impact and investigated economical aspect of such system in comparison with conventional technology consisting separate hot water boiler and air conditioning system. The study was conducted for a five star hotel of 636 rooms, 30 apartments and 25 meeting rooms. The results showed that optimum arrangement of the integration could reduce 36.7% energy consumption for space cooling and hot water supply. This accounted for about 6.6% of total energy use of the hotel. The investigated system was found to be economically viable for hotel application with energy cost reduction for air conditioning and hot water supply systems of 34.4%. The system could also provide reduction on the environmental impact.

1. INTRODUCTION

19
Indonesia, as one of tropical countries, has high potential impact on environment. Greenhouse gases emissions of the country in 2005 have reached 500 million tons CO₂ equivalent with a projection of emissions in 2025 of about 1,185 million tons. The emissions comprise emission from industrial, commercial, domestic and transportation sectors (Purwanto *et al.*, 2006). Most of the country potential impact was resulted from non-renewable energy consumption especially from fossil fuels such as crude oil, natural gas and coal (Hasan *et al.*, 2012).

In commercial sector, energy consumption of the country was 3% of national energy use. The sector includes office buildings, hospitals, hotels, supermarkets and airports. Although the percentage of this sector is quite small but development of this sector is continuously in progress. The growth of hotel industry in past three years for example could reach an average of 11.2% (BPS, 2013). This would consequently increase the energy consumption and environmental impact. The commercial sector, however, has significant potential on energy saving and environmental impact reduction (HAKE, 2014).

Energy use intensity (EUI) for hotels in Indonesia is relatively high. Preliminary observation of four-star hotel in Jakarta (Suamir, 2014) showed that EUI of the hotel was 552 kWh/m²/year in 2012 then down to about 495 kWh/m²/year in 2013. As a comparison, EUIs of hotel industry in some other countries such as UK, New Zealand, Taiwan, Hong Kong, China and Turkey are respectively 368, 159, 295, 342, 165 and 389 kWh/m²/year (Wang, 2012; Deng and Burnett, 2000; Xina *et al.*, 2012; Onut and Soner, 2006). Most of the energy source is from electricity with proportion of 91.7% and LPG (liquid petroleum gas) of 7.8% mainly for hot water production. The hotel also consumed diesel fuel for local electricity generation of about 0.5%. For hotels in Singapore, electricity is also the main energy source, with a proportion of 91% for hotels that only use electricity and gas. For other hotels that also consume diesel fuel for hot water or steam generation, the percentage of electricity drops to 77% (Priyadarsini *et al.*, 2009; Xuchao *et al.*, 2010).

21
Most of the energy use is for air conditioning and hot water systems. For hotel industry, air conditioning and hot water systems are categorized as facilities with significant energy use. Energy consumption of both systems could reach 70% of total energy use. Whilst energy consumption of hotel industries generally account for between 4% and 10% of total running costs or even reaches 20% for luxury hotels (AEE, 2014).

The air conditioning and hot water supply systems are used to satisfy cooling and heating demands. For hotels in Indonesia, the demands are relatively stable through the year. A preliminary study showed that cooling demand varied from 125 to 150 W/m², whilst heating demand especially for domestic hot water system was about 6% - 8% of the cooling demand (Suamir, 2014).

It was also reported that hotels consumed substantial amount of energy (Monfet and Zmeureanu, 2012). In addition, a study on energy consumption of AC systems in hotel buildings has been reported by Barry *et al.* (2013) and it was found that AC system consumed the highest electrical energy among other hotel services. Similar study was also discussed by Yu *et al.* (2012). Thus improving energy efficiency of AC and hot water systems would significantly contribute to energy conservation and certainly reduce operational cost of the hotel industries. As the major part of energy use is produced from electricity, gas and diesel oil products, reducing energy consumption would also contribute to decreasing environmental impact of the sector.

Many researchers have presented their works to maximize energy efficiency and to reduce energy use of the air conditioning and hot water supply systems. Epebasli and Kalinci (2009) reviewed the utilization of heat through heat exchangers and modification of air conditioning and heat pump systems. This comprehensive review is very informative to researchers interested in energetic simulation, analysis, performance assessment and applications of various types of refrigeration based water heater systems.

A novel air-conditioning product, that could achieve the multi-functions with improved energy performance has introduced by Ji *et al.* (2003). It was reported that by incorporating a water heater in the outdoor unit of a split-type air-conditioner. The test system allowed space cooling and water heating could take place simultaneously, therefore the energy performance could be raised considerably. The results showed that average coefficient of performance (COP) for space cooling and water heating was 4.02, while COP for space cooling only and water heating only were obtained 2.91 and 3.42 (at ambient temperature 31°C) respectively.

Another study on seasonal performance evaluation for water heater using an experimental method for rating air source heat pump water heater was presented by Morrison *et al.* (2004). The method was based on measured heat pump performance during the heat-up operation of particular products rather than a generic simulation model. The measured performance was used in a correlation model of the unit in an annual load cycle performance using TRNSYS simulation package. The air source heat pump water heater tested had significant lower performance than typical solar water heater or solar-boosted heat pump water heater. The air source heat pump water heater could be used in applications where solar water heater cannot be considered. It was reported that in winter condition the COP of the system was obtained 2.3 and could provide annual energy saving of 56%.

Further optimization on air source heat pump water heater was presented by Zhang *et al.* (2007). The system investigated comprises a heat pump, a water tank and connecting pipes. Energy of the air was absorbed at the evaporator and pumped to the water tank through the refrigerant cycle. The condenser of the heat pump released heat from refrigerant to the waterside. The system was reported to be possible to heat water from initial temperature to the set temperature of 55°C. The COPs of the system in winter, summer and spring/autumn were obtained 2.61 (at temperature ambient (T_{amb}) = 0°C), 5.66 (for T_{amb} = 35°C) and 4.82 (for T_{amb} = 25°C) respectively.

To date there has not been much research into optimization of air conditioning system through providing simultaneously space cooling and water heating for hotel industry applications. Hotel industry in tropical countries has cooling and water heating demand all year round. Reuse of wasted heat from an air conditioning system for water heater production could improve energy performance of the system and would reduce annual energy consumption of the hotel.

This paper presents theoretical and empirical investigation results of an energy conservation technology on air conditioning (AC) and hot water systems for hotel industry applications by integrating an air source heat pump and a heat recovery system of central AC system. The analyses covers reduction of energy consumption and economic viability of the arrangement compared with conventional system comprises

separate AC system and diesel fuel fired boiler. Environmental impact reduction of a such technology applied for hotel industry is also presented.

2. METHODS AND INTEGRATION CONCEPT

This research was based on experimental and numerical analyses of an integration of heat pump and heat recovery system of a water-cooled chiller. The integrated system was simulated to satisfy heating and cooling demands of a five star hotel with 636 rooms, 30 apartments and 25 meeting rooms located in Bali Island - Indonesia. Experimental method was applied to obtain data from the existing systems of the hotel, while numerical analysis was used to simulate energy and temperature performance of the integrated system. Tests were conducted on the existing chiller system for five days continuously in order to obtain daily data of chiller performance and load factor variation of the chillers operation. Ambient temperature and relative humidity of the tests varied from 26°C to 31°C and from 76% to 88% RH respectively.

Variables to be investigated comprises dependant and independant variables. Dependant variables include energy consumption, cooling capacity and coefficient of performance (COP). Whilst independant variables consist of evaporator and condenser approach temperatures, evaporation and condensation temperatures of refrigerant respectively in evaporator and condenser, chilled and cooling water temperatures, ambient temperature, low and high system pressures, refrigerant flowrate, chilled and cooling water flow rate. The data obtained from experimental test together with data obtained from hotel record and manufacturers were processed simulated by using spreadsheet and *Engineering Equations Solver* programs (EES, 2014). With these programs, energy and temperature performance of the integrated system can be investigated and simulated. The program can also be used to estimate the performance of the system at different operating conditions.

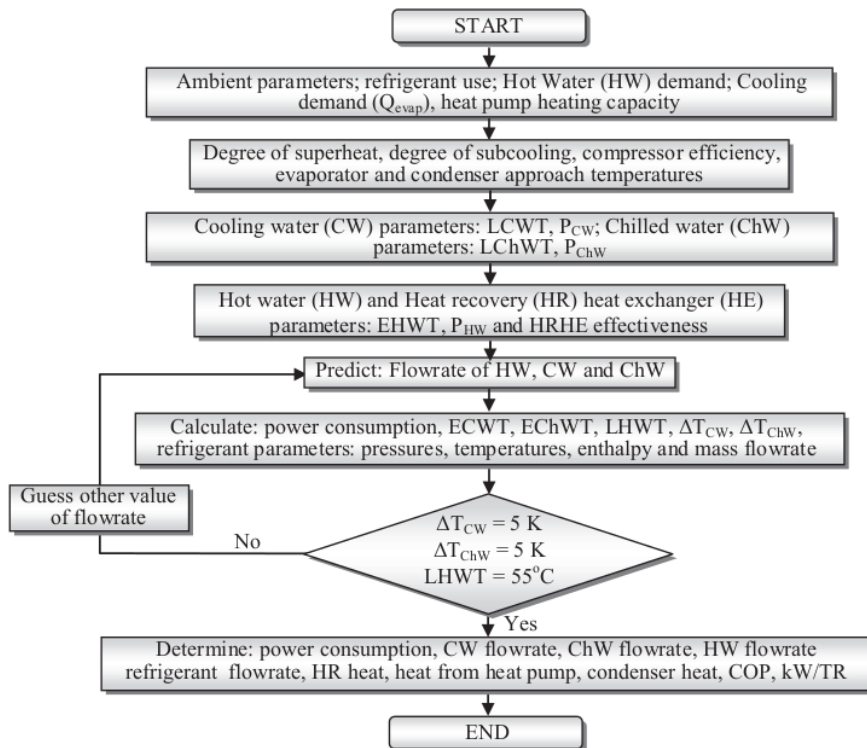

25
E = entering, L = leaving, P = pressure, T = temperature, ΔT = temperature difference, COP = coefficient of performance, TR = ton of refrigeration

Figure 1. Structure of the EES simulation models for integrated heat recovery AC system and heat pump

Figure 1 shows a flowchart of the EES models for integrated heat recovery AC system and heat pump. The model comprises one loop. The loop ensures that the energy balance in the chill⁴¹ condenser, evaporator and heat recovery heat exchanger can be satisfied. The loop determines flowrate of cooling water (CW), chilled water (ChW) and hot water (HW) at a given cooling duty of chiller (which equals to hotel cooling demand). The convergence of the loop is satisfied when the temperature differences of cooling and chilled water have reached 5 K and temperature of hot water exits the heat recovery (HR) heat exchanger of about 55°C. Once the convergence of the loop has been achieved, the power consumption of the compressor and fluid flowrate can be determined and its performance variables (HR heat, COP and kW/TR) can be calculated.

The investigation analyses would cover energy performance, environmental impact and economic viability of the integrated system. Energy performance analysis referred to ASHRAE (2010) and environmental analysis was based on BS EN 378-1 (2008); ASHRAE Standard-34 (2007) and IPCC (2005). Economic viability analysis applied Indonesia energy and equipment prices of the year 2014.

2.1. Existing AC and hot water supply systems

The hotel has one central⁴ plant for its air conditioning system which comprises two water cooled chillers. The schematic diagram of the air conditioning (AC) system can be seen in Figure 2. The chillers utilize centrifugal compressors with cooling capacity of 650 TR (ton of refrigeration) each. The chillers are using R-123 refrigerant. The hotel comprises 50,142 m² air conditioned floor area and 34,878 m² non-air conditioned. All hotel building is situated on 170,000 m² land area, therefore, hotel building services also spread over a very large area. This is why the air conditioning system chosen for the hotel comprises two chilled water loops: primary and secondary loops. Chilled water is circulated throughout the system by primary and secondary pumps as shown in Figure 2.

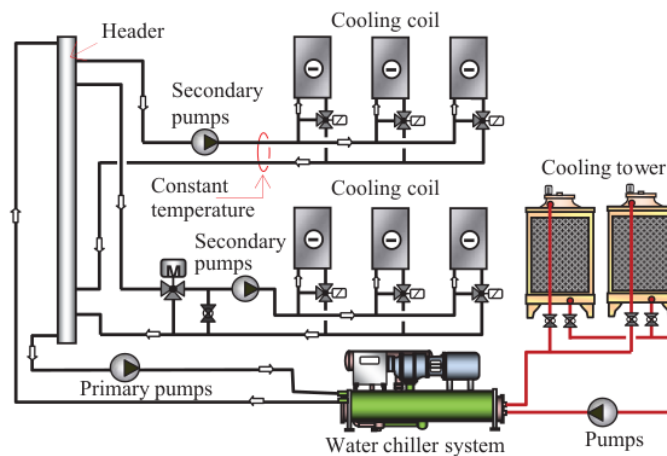

Figure 2. Air conditioning system with water cooled chillers

Main part of the hot water system of the hotel is also placed in the central plant. The system consists of two diesel fuel fired boilers, steam distributor, calorifiers, hot water storages and distribution system. The boilers produce steam of capacity 3.2 ton per hour at 12 bars and 170°C. Boilers supply steam majority for laundry (of about 76%) and small part of 24% for hot water system. The steam supplied to the hot water supply system is flowed to calorifiers to heat cold water of 27°C up to about 55°C. The hot water supply system is also completed with 30 m³ storage which can satisfy hot water demand¹⁵ during the night when the boiler to be shut off due to the laundry is closed. This method of operation can improve the efficiency of the hot water supply system.

2.2. Integration of heat pump¹⁵ and AC systems

The integration of heat pump and air conditioning (AC) system can be seen in Figure 3. The integration system consists of water cooled chiller with heat recovery, heat pump and hot water supply systems. Main supply of the hot water is from the heat recovery system. Heat pump is used for back up when the heat

recovered from the chiller cannot satisfy hot water demand especially during low load factor operation. The hot water supply is also stabilised by utilizing the existing 30 m³ hot water storage which can store the recovered heat during high part load chiller operation and supply the heat when the chiller operated at low load factor. This can also minimise the operation of heat pump and will reduce energy consumption of the hot water production. The calorifiers and boilers of the existing system are not employed in the integration system. The boilers are only used for laundry activities. The chillers applied for the integration system are two sets of 650 TR screw modular chillers with heat recovery to be integrated with 1 unit heat pump of 364 kW heating capacity for back up. Each set of modular chiller comprises 2x200TR modules and 1x250TR module. The chillers and heat pump use R-410A refrigerant specified for hot water production up to 55°C.

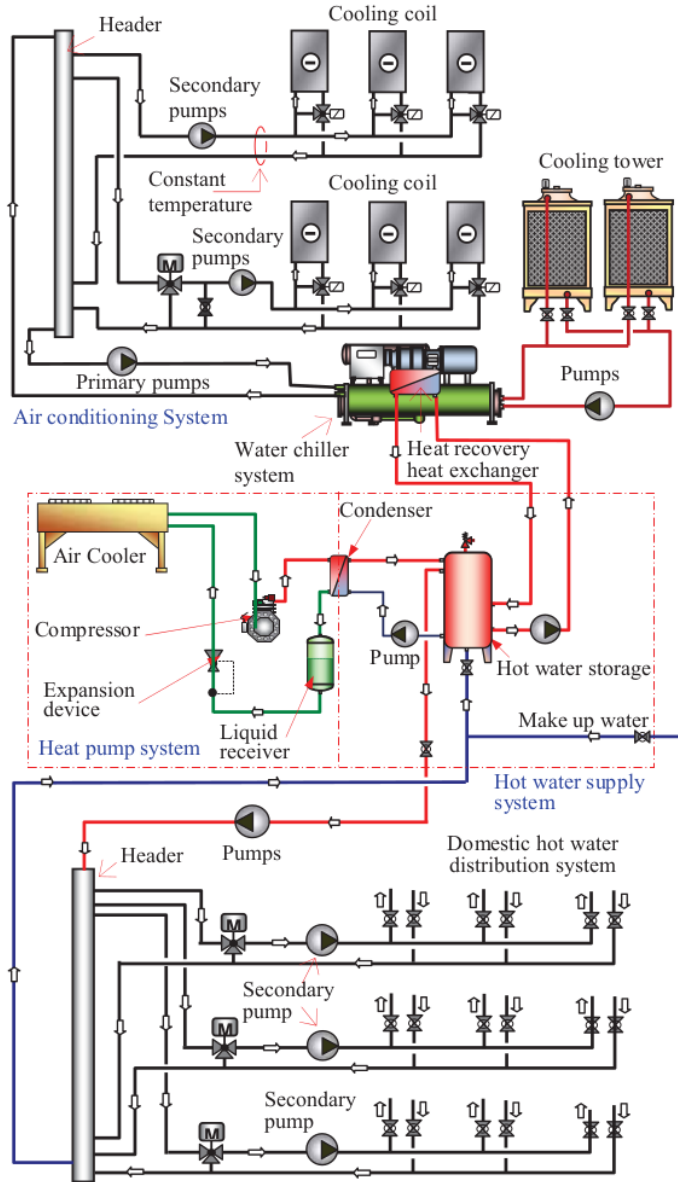

Figure 3. Integration of heat pump and air conditioning system to satisfy space cooling and water heating demands

3. RESULTS AND DISCUSSION

Calculation results on energy use based on the data obtained from the hotel showed that facility services of the hotel use two energy types which include electricity and diesel fuel. Electricity is the main energy source accounting for 63.7% and consumption on diesel fuel of about 36.3% of total energy use. Total energy consumption for facility services based on energy data 2012 and 2013 is 23,260 MWh/year. The electrical energy is mainly used for AC system, refrigeration, lighting and a pumping system. Electrical energy consumption of the hotel was calculated to be 14,815 MWh/year. Energy use intensity (EUI) of the hotel calculated for two-year period 2012 and 2013 was to be 426.9 kWh/m²/year. This is still considered high compared with EUI of hotels in other countries as described previously in the introduction.

There is no data available for hot water use of the hotel. Then energy use for the existing hot water system was estimated using data from similar type of hotels in Indonesia which have data record for hot water supply system. Hot water demand of 55°C supply temperature is assumed to be 200 liters/room/day. Total rooms of the hotel including villas and apartment are 672 rooms. Then, it can be determined the hotel hot water demand of 134,400 litres/day with heat energy demand as high as 5,752,503 MJ/year. The heat energy demand was calculated based on makeup water temperature of 27°C. Assuming the efficiency of the boiler of 80%, diesel fuel energy for hot water supply was found to be 7,190,629 MJ/year or 1,998 MWh/year accounting for 23.65% of total diesel fuel energy of the hotel. The rest of diesel fuel energy is for laundry equipment.

Analysis results on the energy and environmental performance of the existing system as well as the integration system are shown in Table 1. In operation with the same annual load ratio, annual average COP and efficiency of the existing chillers are more favourable than the chillers of the integrated system (to be considered for cooling only). This is because of the existing system using centrifugal chillers, which commonly have better performance compared with screw type chillers. The results, however, also showed that total annual energy consumption of integration system is much lower of 36.7% than the existing air conditioning and hot water supply system. This reduction accounted for 6.6% of total energy use of the hotel and mainly due to very low energy used, if not free, for hot water production. For the integration system, the hot water was produced from wasted heat of the chillers through heat recovery heat exchangers. The simulation also showed that with 30 m³ hot water storage and the chillers operated in the range of investigated load factor, all of the hotel hot water demand can be satisfied by heat recovery system. The heat pump system would be in operation when the chillers run with very low load factor for a long time until the heat storage and heat recovery system could not cope with the heating demand. However, for this simulation, the heat pump was assumed to run 4 hours per day (from 5 a.m. up to 9 a.m.).

Table 1 Summary of Energy and Environmental analyses of the integrated system

No	Parameters	Existing system	Integrated system
1	Energy Performance		
	Annual COP	5.99	5.20
	Annual efficiency (kW/TR)	0.59	0.68
	Annual part load (%)	64.12	64.12
	Annual electricity for Chiller (MWh)	2,173	2,486
	Annual electricity for HW from heat pump (MWh)	-	156
	Annual electricity (MWh)	2,173	2,642
	Annual diesel fuel for HW (MWh)	1,998	-
	Total annual energy (MWh)	4,171	2,642
2	Environmental Impact		
	Indirect impact (tonCO ₂ /year)	1,554	1,777
	Direct impact (tonCO ₂ /year)	7	129
	Indirect impact from diesel fuel (tonCO ₂ /year)	532	-
	Total impact (tonCO ₂ /year)	2,093	1,906
	ODP (ozone depleting potential)	0.02	0.00

COP = Coefficient of performance; TR = ton of refrigeration (12000 BTU/h); HW = hot water ; Carbon dioxide intensities for Indonesia electricity and diesel fuel were 0.715 and 0.267 kgCO₂/kWh respectively (IPCC, 2005)

38
Table 1 also shows environmental impact of the existing system is higher about 10% than the integration system. The existing and integration systems are responsible for 2,093 and 1,906 tonCO₂/year respectively. Another downside of the existing system is that the chillers still use refrigerant R-123, which has ODP of 0.02. The phase out of this refrigerant for Indonesia will be in 2040. Time limitation is necessary to be considered when using refrigerant R-123.

Economic viability of the integration system in comparison with the existing system comprises separate air conditioning and diesel fuel fired boiler is shown in Table 2. From the table, it can be seen that the integrated system can provide considerably low payback period of 2.61 years with cost saving more than 1.7 billion rupiahs (IDR) per year. As described previously, the heat pump system is mainly for backing up system. The simulation results actually showed that the heat recovery system of the chiller could satisfy the hotel heating demand. Considering this results if the hot water supply fully employs the heat recovery system (without heat pump), the cost component of heat pump can be omitted. Then the cost saving would increase up to more than 1.8 billion IDR per year with payback period of 1.48 years. The investigation on the economic viability also found that cost saving of the integrated system is dependent on energy efficiency of the system and cost ratio between diesel fuel and electrical energy. Cost saving will increase when cost ratio goes higher.

Table 2 Summary of economic viability of integrated system

No	Parameters	Existing system	Integrated system
1	Cost components		
	Investment cost (MRp)	-	4,517.17
	Chiller operational cost (MRp/year)	2,689.22	3,132.24
	Hot water supply cost (MRp/year)	2,330.29	159.20
	Total operational cost (MRp/year)	5,019.51	3,291.44
2	Cost saving (MRp/year)		1,728.07
3	Payback period (years)		2.61

MRp = million rupiahs; Diesel fuel cost = Rp 11,600/litre or Rp 1,167/kWh; Electricity cost = Rp 1,237.5 (it has considered tax, peak and non peak hours and load cost); Rp = IDR (Indonesian rupiah)

Other advantage of the integration system consisting modular chillers system is that the AC system can accommodate cooling load variation and can work at relatively stable performance although at low load factor. The integrated system, however, has also drawback as its disadvantage such as the size of modular chiller set is usually wider than single chiller system. Available space in the plant room needs to be checked and considered accordingly to suit the system installation.

4. CONCLUSIONS

34
Experimental and numerical investigations have been conducted on the integration of heat pump and heat recovery system of a water cooled chiller system for hotel industry applications. The results showed that total annual energy consumption of integration system is significantly lower than the existing system comprises separate air conditioning and hot water supply systems. It was also found that by utilizing 30 m³ hot water storage, hot water demand of the hotel can be satisfied from heat recovery system without heat pump.

Environmental performance of the integration system is more favourable with CO₂ emissions reduction of 10%. The existing and integration systems are responsible for 2,093 and 1,906 tonCO₂/year respectively. With regards to the economic viability, the integration system can provide considerably low payback period of 2.61 years with cost saving more than 1.7 billion rupiahs (IDR) per year. This accounted for 34.4% reduction on energy cost of air conditioning and hot water supply systems.

7 5. ACKNOWLEDGMENT

The authors acknowledge the financial support received from the Higher Education Directorate General of the Ministry of Research, Technology and Higher Education of the Republic of Indonesia.

6. REFERENCES

- AEE. 2014, *Energy conservation of you need to know*. Available from <http://www.aeecenter.org>
- ASHRAE Standard 34. 2007, *Designation and safety classification of refrigerants*. ASHRAE Inc., Atlanta.
- ASHRAE. 2010, *ASHRAE handbook of refrigeration*. ASHRAE Inc., Atlanta, 749 p.
- Barry L, Mak BL, Chan WW, Li D, Liu L, Wong KF. 2013, Power consumption modeling and energy saving practices of hotel chillers, *Int. J. Hospitality Management* 33: 1-5
- BPS. 2013, *Selected indicators Social-Economic of Indonesia*. Available from <http://www.bps.go.id>
- BS EN 378-1. 2008, *Refrigerating systems and heat pumps - Safety and environmental requirements: Part 1 - Basic requirements, definitions, classification and selection criteria*. BSI, UK, 68 p.
- Deng S, Burnett J. 2000, A study of energy performance of hotel buildings in Hong Kong, *Energy and Buildings* 31: 7-12
- EES, 2014. *Engineering equations solver*. www.fChart.com
- HAKE. 2014, *Upgrading and Leveraging Indonesia to Fortify Energy Efficiency through Academic and Technical Trainings for Energy Management Professionals*, UPLIFT program, Jakarta, 631 p.
- Hasan MH, Mahlia TMI, Hadi Nur. 2012, A review on energy scenario and sustainable energy in Indonesia, *Renew. Sustain. Energy Rev.* 16: 2316-2328
- Hepbasli A, Kalinci Y. 2009, Review of heat pump water heating systems. *Renewable and Sustainable Energy Reviews* 13: 1211-1229
- IPCC. 2005, *Safeguarding the ozone layer and the global climate system. UN-Intergovernmental Panel on Climate Change*. 478 p. Available from: [http:// arch.rivm.nl/env/int/ipcc/pages_media/SROC-final/SpecialReportSROC.html](http://arch.rivm.nl/env/int/ipcc/pages_media/SROC-final/SpecialReportSROC.html)
- Ji J, Chow T, Pei G, Dong J, He W. 2003, Domestic air-conditioner and integrated water heater for subtropical climate. *Appl. Therm. Eng.* 23: 581-592
- Monfet D, Zmeureanu R. 2012, Ongoing commissioning of water-cooled electric chillers using benchmarking models, *Appl. Energy* 92: 99-108
- Morrison G, Anderson T, Behnia M. 2004, Seasonal performance rating of heat pump water heaters. *Solar Energy* 76: 147-152
- Onut S, Soner S. 2006, Energy efficiency assessment for the Antalya Region hotels in Turkey, *Energy and Buildings* 38: 964-971
- Priyadarsini R, Xuchao W, Eang LS. 2009, A study on energy performance of hotel buildings in Singapore, *Energy and Buildings* 41: 1319-1324
- Purwanto WW, Nugroho YS, Dalimi R, Soepardjo AH, Wahid A, Supramono D, Herminna D, Adilina TA. 2006, *Indonesia Energy Outlook and Statistics*, Pengkajian Energi UI, Jakarta, 276 p.
- Suamir IN. 2014, *Chillers and AC system performance main building and tower building of Mercure Convention Center-Jakarta for energy and temperature performance improvement*, Energy audit report, Jakarta, 70 p.
- Wang JC. 2012, A study on the energy performance of hotel buildings in Taiwan, *Energy and Buildings* 49: 268-275
- Xina Y, Lua S, Zhua N, Wu W. 2012, Energy consumption quota of four and five star luxury hotel buildings in Hainan province China, *Energy and Buildings* 45: 250-256
- Xuchao W, Priyadarsini R, Eang LS. 2010, Benchmarking energy use and green house gas emissions in Singapore's hotel industry, *Energy Policy* 38: 4520-4527
- Yu FW, Chan KT, Sit RKY. 2012, Climatic influence on the design and operation of chiller systems serving office buildings in a subtropical climate, *Energy and Buildings* 55: 500-507
- Zhang J, Wang RZ, Wu JY. 2007, System optimization and experimental research on air source heat pump water heater, *Appl. Therm. Eng.* 27: 1029-1035.

ORIGINALITY REPORT

18%

SIMILARITY INDEX

10%

INTERNET SOURCES

13%

PUBLICATIONS

6%

STUDENT PAPERS

PRIMARY SOURCES

- | | | |
|---|--|----|
| 1 | Hepbasli, A.. "A review of heat pump water heating systems", Renewable and Sustainable Energy Reviews, 200908/09
Publication | 2% |
| 2 | refportal.com
Internet Source | 1% |
| 3 | Submitted to Waterford Institute of Technology
Student Paper | 1% |
| 4 | "Proceedings of the 8th International Symposium on Heating, Ventilation and Air Conditioning", Springer Science and Business Media LLC, 2014
Publication | 1% |
| 5 | Wu Xuchao, Rajagopalan Priyadarsini, Lee Siew Eang. "Benchmarking energy use and greenhouse gas emissions in Singapore's hotel industry", Energy Policy, 2010
Publication | 1% |
| 6 | solar1.mech.unsw.edu.au
Internet Source | 1% |
-

7	www.atlantis-press.com Internet Source	1 %
8	Zhao, Liang, Ruobing Liang, Jili Zhang, and Xiwang Kou. "Research on the performance of the household-type cooling-heating-hot unit in winter", <i>Applied Thermal Engineering</i> , 2015. Publication	1 %
9	I N Suamir, Sudirman, I N Ardita, G Santanu. "Experimental and numerical optimization on chilled water configuration for improving temperature performance and economic viability of a centralized chiller plant", <i>Journal of Physics: Conference Series</i> , 2020 Publication	1 %
10	Submitted to University of Derby Student Paper	<1 %
11	ijettjournal.org Internet Source	<1 %
12	www.iiste.org Internet Source	<1 %
13	Fernandez-Seara, J.. "Experimental analysis of a direct expansion solar assisted heat pump with integral storage tank for domestic water heating under zero solar radiation conditions", <i>Energy Conversion and Management</i> , 201207 Publication	<1 %

14 Putu Wijaya Sunu, Daud Simon Anakottapary, A.A.N.B. Mulawarman, I D M Cipta Santosa, I Putu Sastra Negara. "Heat Transfer Characteristics of Fan Coil Unit (FCU) Under The Effect of Chilled Water Volume Flowrate", Journal of Physics: Conference Series, 2018
Publication

15 Ibrahim, Oussama, Farouk Fardoun, Rafic Younes, and Hasna Louahlia-Gualous. "Review of Water Heating Systems: General Selection Approach based on Energy and Environmental Aspects", Building and Environment, 2013.
Publication

16 Shadananda Acharya, Shree Raj Shakya. "Energy demand analysis of a five star hotel in Nepal- A case study of Bhairahawa, Nepal.", Journal of Innovations in Engineering Education, 2021
Publication

17 jthmnet.com
Internet Source

18 Submitted to Brunel University
Student Paper

19 Suamir, I Nyoman. "Solar Driven Absorption Chiller for Medium Temperature Food Refrigeration, a Study for Application in

Indonesia", Applied Mechanics and Materials, 2014.

Publication

20

Kahraman, Ali, and Alaeddin Añelebi. "Investigation of the Performance of a Heat Pump Using Waste Water as a Heat Source", Energies, 2009.

Publication

21

Masa-Aki Ochiai. "A very small LWR installed in the underground in the city", Progress in Nuclear Energy, 2000

Publication

22

Sami Missaoui, Zied Driss, Romdhane Ben Slama, Bechir Chaouachi. "Experimental and numerical analysis of a helical coil heat exchanger for domestic refrigerator and water heating", International Journal of Refrigeration, 2022

Publication

23

sintadev.ristekdikti.go.id

Internet Source

24

"IEC 61850 Principles and Applications to Electric Power Systems", Springer Science and Business Media LLC, 2023

Publication

25

repository.unri.ac.id

Internet Source

<1 %

<1 %

<1 %

<1 %

<1 %

<1 %

26	tci-thaijo.org Internet Source	<1 %
27	Chen, H.. "Combined space cooling and water heating system for Hong Kong residences", <i>Energy & Buildings</i> , 201002 Publication	<1 %
28	Jiang, H.. "An experimental study on a modified air conditioner with a domestic hot water supply (ACDHWS)", <i>Energy</i> , 200609 Publication	<1 %
29	TADAKATSU OHNAKA, YUTAKA TOCHIHARA, YUMIKO WATANABE. "The effects of variation in body temperature on the preferred water temperature and flow rate during showering", <i>Ergonomics</i> , 1994 Publication	<1 %
30	docs.neu.edu.tr Internet Source	<1 %
31	dspace.khazar.org Internet Source	<1 %
32	edepot.wur.nl Internet Source	<1 %
33	nanopdf.com Internet Source	<1 %
34	portal.dl.saga-u.ac.jp Internet Source	<1 %

35	theses.lib.polyu.edu.hk Internet Source	<1 %
36	vital.seals.ac.za:8080 Internet Source	<1 %
37	www.cibsejournal.com Internet Source	<1 %
38	www.hbku.edu.qa Internet Source	<1 %
39	www.researchgate.net Internet Source	<1 %
40	S. Toepfl, A. Mathys, V. Heinz, D. Knorr. "Review: Potential of High Hydrostatic Pressure and Pulsed Electric Fields for Energy Efficient and Environmentally Friendly Food Processing", Food Reviews International, 2006 Publication	<1 %
41	Shutong Yang, Youlei Wang, Yufei Wang. "Optimization of Cascade Cooling System Based on Lithium Bromide Refrigeration in the Polysilicon Industry", Processes, 2021 Publication	<1 %
42	Allen H. Hu, Ching-Yao Huang, Chi-Fu Chen, Chien-Hung Kuo, Chia-Wei Hsu. "Assessing carbon footprint in the life cycle of accommodation services: the case of an international tourist hotel", International	<1 %

Journal of Sustainable Development & World Ecology, 2015

Publication

Exclude quotes On

Exclude matches Off

Exclude bibliography On