

PAPER • OPEN ACCESS

## Experimental Study on the Prospective Use of PV Panels for Chest Freezer in Hot Climate Regions

To cite this article: IN Suamir *et al* 2020 *J. Phys.: Conf. Ser.* **1569** 032042

View the [article online](#) for updates and enhancements.



**IOP | ebooks™**

Bringing together innovative digital publishing with leading authors from the global scientific community.

Start exploring the collection—download the first chapter of every title for free.

# Experimental Study on the Prospective Use of PV Panels for Chest Freezer in Hot Climate Regions

IN Suamir<sup>1,\*</sup>, IGAB Wirajati, IDMC Santosa, IDM Susila and IDGA Tri Putra,

<sup>1</sup>Mechanical Engineering Department, Bali State Polytechnic, Bali, 80364, Indonesia

\*Email: nyomansuamir@pnb.ac.id

**Abstract.** Chest freezer is one of the commercial refrigeration systems used for keeping foods nutritious and healthy. In its operation, a chest freezer requires transient loads that fluctuate from time to time accordingly with environmental conditions. To be able to satisfy the cooling load, uninterrupted power should be supplied. Photovoltaic (PV) power supply system can provide continuous, independent and reliable electrical energy at the point of use. This can make it particularly suitable to be used for remote region and boost the use of renewable energy. This study investigated the potential use of PV power supply system for a chest freezer in Indonesia as a hot climate region. A solar PV-powered chest freezer has been established to experimentally investigate its daily operating performance. Electrical energy generated, stored and consumed by the system was recorded and analyzed. A well-matched electrical power generated by solar PV system and consumed by a chest freezer was determined. Detailed results obtained during daily experimental measurements are also presented. The study results showed that solar PV panels applied for chest freezer in hot climate region is amazingly prospective.

## 1. Introduction

Solar photovoltaic (PV) power supply systems have shown their prospective use in rural area with lack of electrification. With the price of PV panels tends to decrease, applications of the PV power supply system are economically becoming attractive and growing. The use of PV system widely spread in social and communal services, agriculture and other productive activities, which can have a significant impact on rural development. PV systems used varies from very small applications such as for lighting to mid-scale applications like solar home system such as several lamps, television and computer of capacity ranging from 130 watts peak (Wp) to 250 Wp [1-3].

There is, however, still a lack of information on the potential and limitations of PV applications especially for food preservation such as refrigerator and freezer. A study on a multi-purpose PV-refrigerator system has reported that PV-refrigerator system could reliably use where the local grid is intermittently available or regions are not properly electrified whereas the demand of refrigeration is essential [4]. At simulation stage, analysis and simulation of solar driven refrigeration system using variable speed compressor at real weather conditions has been reported in [5]. The simulation can be used to estimate energy performance of a direct solar PV refrigeration system using variable speed compressor evaluated at particular weather conditions. Most of the published researches on solar refrigeration were based on absorption or adsorption refrigeration systems, where solar energy is used to indirectly heat the generator through a medium heat transfer as reported in some researches [6-11].



This paper presents effort through innovative integrated renewable energy technologies applied for solar powered refrigeration system that employ natural refrigerants such as in chest freezer. The investigation was based on Indonesia weather conditions. As a huge archipelago country laid across the world equator, Indonesia has intensive value of solar irradiation ranges between 4.6 kWh/m<sup>2</sup> and 7.2 kWh/m<sup>2</sup>. This indicates that the country has high solar energy potential [12-13]. However, the total capacity of solar energy utilization, especially PV panels, is only around 42.78 MW accounted for only 0.03% of the total energy consumption and around 0.41% of the total renewable energy use [14]. The portion of solar energy use in the country is still minor. Therefore, solar refrigeration technology can contribute to the improvement of the use of renewable energy in the country.

In addition of that, the country also needs extensive investment for efficient technologies that can encourage development of cold storage infrastructure from small capacity such as refrigerator and chest freezer. The demands are due to the country has experienced unbalanced food supply and demand which may need to be well-adjusted through import policy. Unbalanced food supply can boost the price of food, sometimes reaching unreasonable level which very much affects the lives of low income populations. This is one of the challenges for the country in improving food security and sustainability. Furthermore, Indonesia is the second highest producers of fishery and aquaculture products in the world [15]. Fishery and aquaculture production of the country in 2014 was 14.33 million tons. In 2016, the production reached 23.03 million tons which 27.6% came from marine fisheries and 72.4% from aquaculture [16]. While the development of cold storage include chest freezer for fishery industry in Indonesia is less than satisfactory. Indonesia is also on the list of low index cold storage markets with abundant natural resources [17]. The lack of cold storage facilities has greatly restricted the development of its fishery industry. The current infrastructure is also too poor to exploit the resources efficiently. Moreover, Indonesia as one of lower-middle income economies is in the burgeoning stages of retail and cold chain development. In 2016, the country has cold storage capacity of 12.3 million m<sup>3</sup> with Cold Chain Competiveness Scorecard 4 out of 7 [15,17]. Under this circumstance, the country needs extensive investment for efficient technologies that can encourage development of cold storage infrastructure from small capacity such as solar refrigerator and solar chest freezer to large capacity such solar refrigerated warehouse.

## 2. Description of Solar PV Test System

Schematic of the solar PV-powered chest freezer which comprises a PV power supply system and a chest freezer system is presented in Figure 1. The PV power supply system is composed of five main parts: i) the solar PV panels; ii) the solar charge controller; iii) the energy storage unit (100 Ah battery); iv) the pure sine wave inverter 12 VDC-220 VAC 1000 W; and v) the automatic transfer switch (ATS). The chest freezer used is an energy efficient and environmentally friendly standalone refrigeration unit charged with R600a (a natural refrigerant). The chest freezer is specified for 100 W power input and 220 VAC. Energy demand of PV-chest freezer system was provided by two photovoltaic panels 12VDC 150 Wp connected in parallel. Photovoltaic panels used are monocrystalline type due to higher efficiency compared with the polycrystalline type. Specification of the solar panel is presented in Table 1.

The solar charge controller unit regulates the DC output from the PV panels, and supplies solar energy to the battery unit. The control unit prevents the battery from over-charged and full discharged. The battery system consists of a single 100 Ah - 12 VDC dry-type battery. The pure sine wave inverter changes the voltage of 12 V power supplied from the battery system to 220 VAC delivered to the chest freezer through the ATS unit. The inverter unit has a capacity of 1000 W. This capacity is required to accommodate power demand fluctuation of the chest freezer especially during “start” in the cycling mode “on-off”. The ATS unit provided in the solar PV power supply system to make the system possible to use the power either supplied from the solar power supply system or national grid. This provides high flexibility to the PV-chest freezer unit. In the PV-chest freezer system, the selection and proper installation of appropriately-sized components directly affects system flexibility, reliability, lifetime, and initial cost. By using more batteries and increasing the number of PV panels array may

extend the lifetime and reliability of a PV system designed for a specific use. This will, however, increase the initial cost of the solar PV power supply system. Number of panels in the PV power supply array and the size of battery storage capacity vary depending on site location.

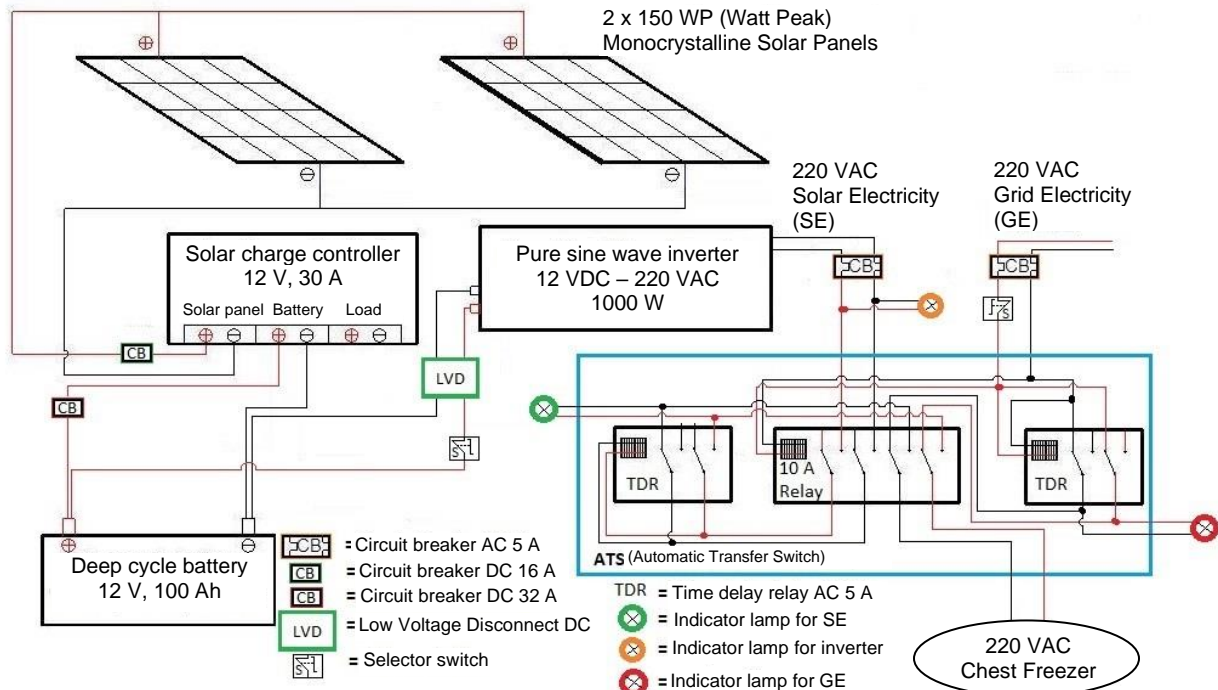

**Figure 1.** Schematic diagram of PV experimental test system

**Table 1** Specification of the 150 WP monocrystalline solar panel used in the investigation

Parameters	Value	Parameters	Value
Maximum power $P_{max}$ (WP)	150	Panel size (mm)	1476 x 671 x 30
Voltage at $P_{max}$ (V)	18	Weight (kg)	10.2
Current at $P_{max}$ (A)	8.33	Cell size (mm)	156 x 156
Open circuit voltage (V)	21.6	Number of cells	36
Short circuit current (A)	9.17	Cells type	Mono-crystalline silicon

### 3. Experimental Test Method

The investigation was conducted at Bali State Polytechnic situated in south part of Bali Island. Data were recorded in July 2019. A data logger of 32 channels was used in the measurement system; 16-channels were used in measurements of the chest freezer parameters, 8 channels for temperature ambient and the surface of the solar panel. Power analyzers were used for measuring the current, voltages and power. The inside temperature of the chest freezer, indoor and outdoor air temperatures were measured using K type thermocouples with  $\pm 1^\circ\text{C}$  accuracy and  $0.5^\circ\text{C}$  linearity. The current and voltage values at the output of the PV panels and chest freezer were measured to determine the energy produced by the PV panels and the energy consumed by the chest freezer. Data were recorded to data logger for 10 min intervals. Solar radiation values were measured with Lutron Solar Power Meter SPM-1116SD with  $10\text{ W/m}^2$  accuracy and  $0.1\text{ W/m}^2$  resolutions for irradiance lower than  $1000\text{ W/m}^2$  and resolution of  $1\text{ W/m}^2$  for irradiance higher or the same as  $1000\text{ W/m}^2$ . Recorded data from the measurement systems were processed and analyzed. Performance parameters of the solar power supply system such power generated, electricity intensity, efficiency and power consumption by the

chest freezer were calculated and presented. Further calculations and graphs manipulation were processed by using spread sheet program.

## 4. Results and Discussion

### 4.1. Solar Irradiation Intensity

The instantaneous values of solar irradiation applied for the PV-chest freezer system were obtained for a typical hot day at Bali State Polytechnic in Bali Island. Experimental study was started at local time of 6.50 a.m. for a period of 48 hours. Figure 2 shows potential of solar irradiation in the area of experimental test location measured for a test period of 48 hours on the adjacent surface parallel to the PV panels. From the figure, it can be seen that direct irradiancies have high potential for electrical energy generation. Maximum values of solar direct irradiancies were observed from 11 a.m. to 1 p.m. in the range between 1050 and 1150  $\text{W}/\text{m}^2$ . Sunshine duration for day-1 and day-2 are 11.5 h and 12.3 h respectively. Average solar irradiancies for day-1 and day-2 can be determined to be 737 and 701  $\text{W}/\text{m}^2$  respectively. From published articles, the solar radiation in Bali Island can be detailed as shown in Table 2.

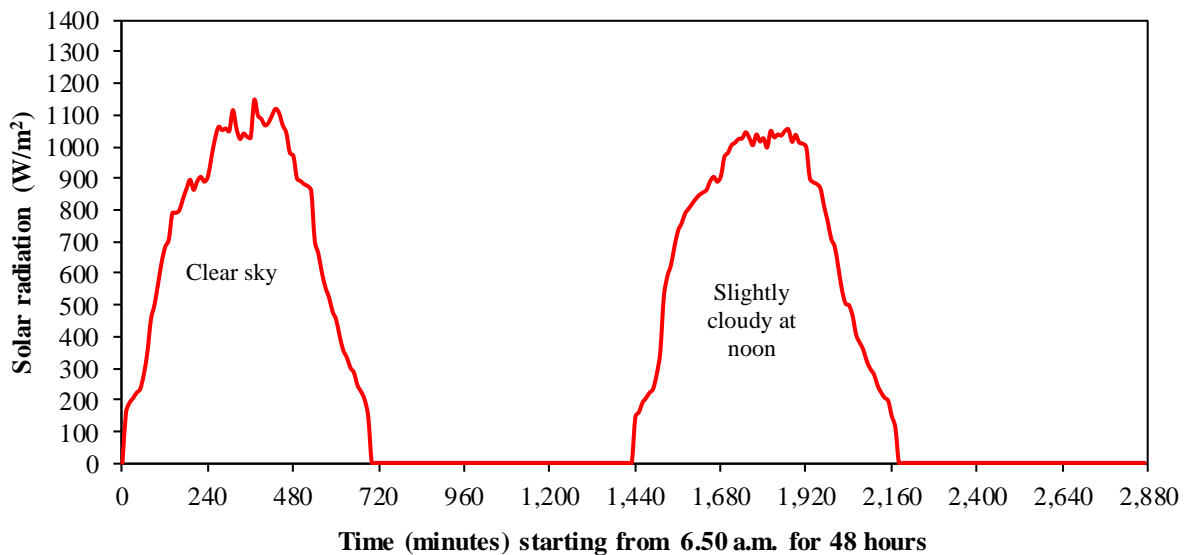

**Figure 2.** Potential of solar radiation in the area of experimental test location measured for a test period of 48 hours on the adjacent surface parallel to the PV panels.

**Table 2** Potential of solar radiation in Bali Island [18,19]

	Beam radiation ( $\text{W}/\text{m}^2$ )	Diffuse radiation ( $\text{W}/\text{m}^2$ )	Monthly radiation ( $\text{kWh}/\text{m}^2/\text{month}$ )	Solar hours (hours/month)	Wet day (days)
January	874	139	167.09	390.6	16
February	872	138	152.88	347.2	13
March	878	127	173.91	378.2	10
April	854	119	168.30	357.0	6
May	829	112	160.58	362.7	5
June	822	107	148.20	348.0	5
July	838	107	158.10	362.7	4
August	853	119	176.70	365.8	3
September	865	131	188.10	363.0	3
October	848	150	202.12	381.3	6
November	846	152	183.30	375.0	8
December	866	141	167.09	390.6	13
	<b>854</b>	<b>129</b>	<b>2046.37</b>	<b>4422.1</b>	<b>92</b>

Daily radiation average 5.61  $\text{kWh}/\text{m}^2/\text{day}$ , with daily day length average of solar radiation 12.12 hours

#### 4.2. Solar Electrical Power Generation

Figure 3 shows instant solar electrical power generated by PV-power supply system and instant electrical power consumed by the chest freezer for a test period of 48 hours. Average instant power generated by PV system for day-1 and day-2 are respectively 136.4 W in a period of 11.5 h and 108.2 W in 12.3 h. While average instant power consumed by chest freezer for 48-hours test is measured to be 88.8 W. During the test (48 h) the chest freezer was experiencing “on-off” cycles, with “on cycles” for about 32.5 h and “off cycles” for 15.5 h. The instant power generated by the PV power supply system during solar hours is much higher than the instant power consumed by the chest freezer. The excess power was stored in the battery system which can be used during non-solar hours.

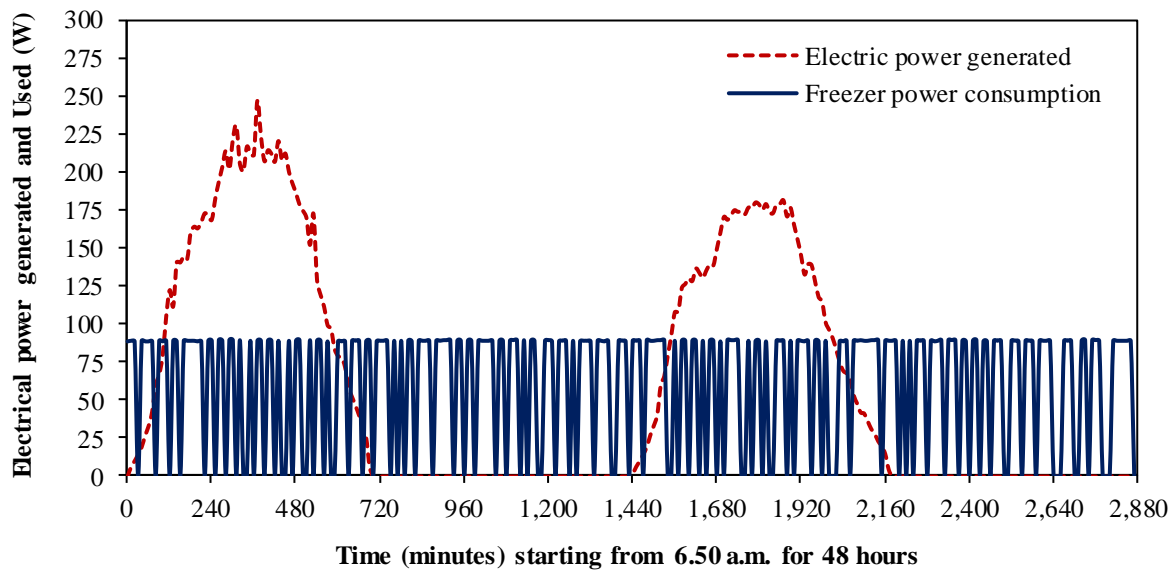

**Figure 3.** Electrical power generated by PV system and used by chest freezer for a period of 48 hours

#### 4.3. Solar PV Energy Generation and Efficiency

Instant electrical-power intensity generated by the PV-power supply system is presented in Figure 4. The power intensity generated ranges from 0 to about 140 W per  $\text{m}^2$  of PV panel surface area. Maximum instant power intensity of day-1 was found to be 140  $\text{W}/\text{m}^2$  which was higher than the power intensity of day-2 of 102  $\text{W}/\text{m}^2$ .

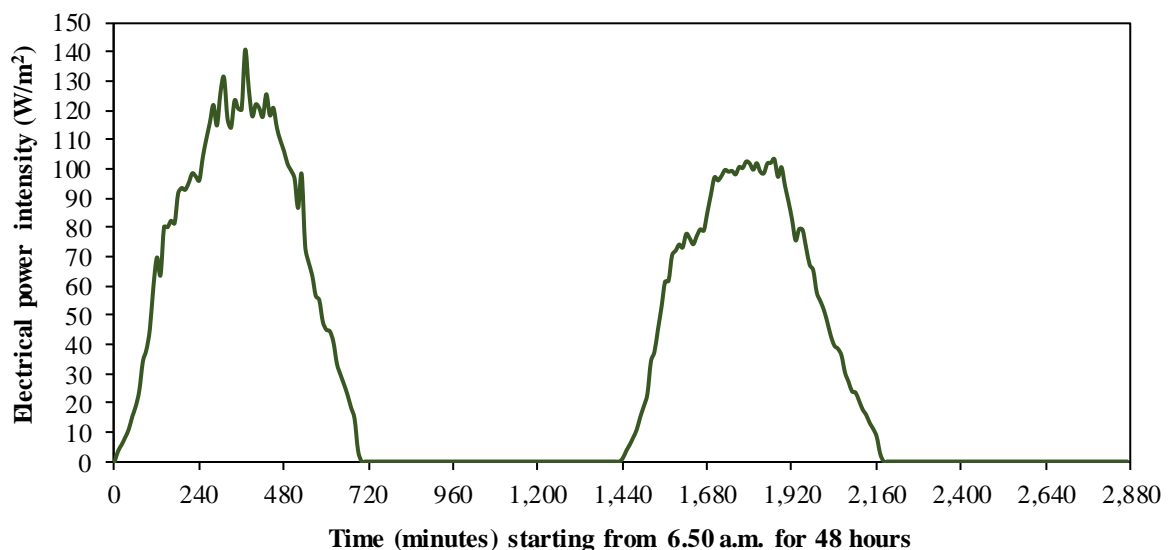

**Figure 4.** Electrical power generated per  $\text{m}^2$  of the solar PV panels for a test period of 48 hours

Average instant power intensity of day-1 was found to be  $77.8 \text{ W/m}^2$  which was higher than day-2 of about  $61.8 \text{ W/m}^2$  which were delivered in 11.5 hours and 12.3 hours respectively.

Electrical energy generated by the PV-power supply system and consumed by the chest freezer is shown in Figure 5. The solar energy generated in day-1 and day-2 was about 1568 Wh and 1335 Wh respectively with average energy per day of 1451 Wh. While daily energy consumption of the chest freezer was found to be 1450 Wh. This indicated that the solar PV power supply system could generate electrical energy that was just enough to satisfy energy consumed by the chest freezer. Theoretically the chest freezer system can be fully powered by the PV-power supply system. Practically the power supply system cannot deliver all stored energy to the chest freezer especially during non-solar day period. The charge controller limits the minimum charge available in the battery system and prevents the battery from fully discharged. This makes the chest freezer system cannot continuously work if it only uses the energy of PV power system. For the investigated system, however, it does not matter due to the system is completed with ATS system that allows energy to be supplied from the national grid. Moreover, using the current solar PV panels (300 Wp capacity), the battery was only 54% charged. There is 46% idle capacity of the battery. In order to obtain a solar chest freezer that fully powered by renewable energy and optimize the battery system use, the capacity of the PV panel should be made bigger than the existing PV panels.

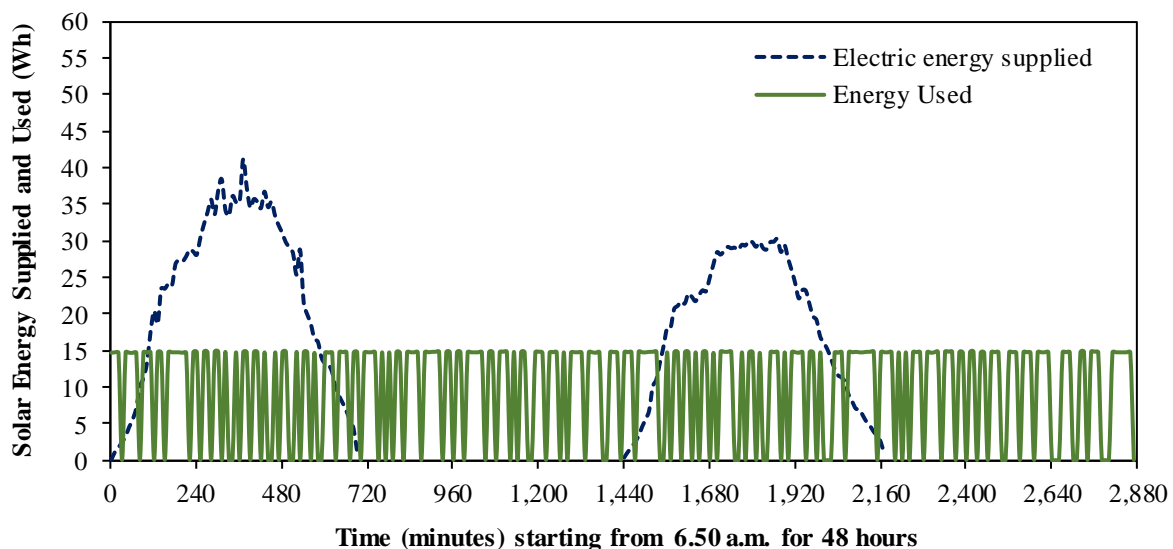
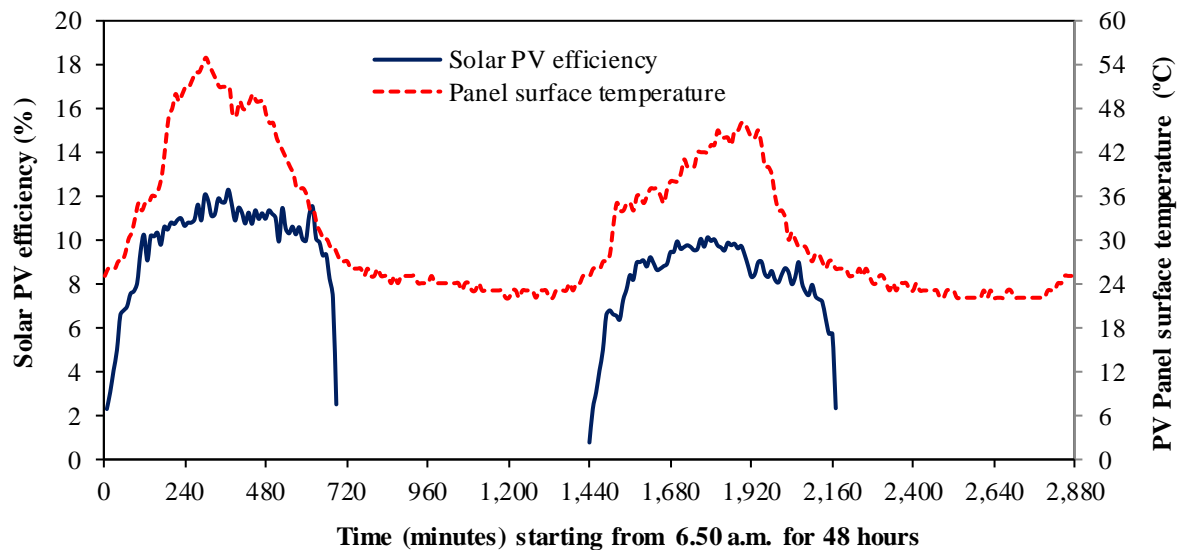

**Figure 5.** Electrical energy generated from the PV system and energy used by the chest freezer for a test period of 48 hours

Availability of solar energy is very much subject to major short-term fluctuations such as a heavy cloud that may occur in the rainy season can reduce the level of irradiation to the lowest fraction of its highest level. This can be proof from the day-2 test, with slightly cloudy weather conditions the level of solar energy harnessed significantly dropped from 1568 Wh to 1335 Wh. Other factors in the environment of the PV panel installation also need to be considered such as buildings, trees can also cut down the solar energy generated by the PV panels.

For standalone PV-chest freezer, it is recommended to make the capacity of the solar power supply system bigger. A PV panels of capacity 400 Wp is estimated to be enough to satisfy the energy demand of the chest freezer. Using bigger PV panels, the 1000 Ah battery can be almost fully charged during the solar hours with energy excess to be stored in the battery of 1255 Wh of 1440 Wh at fully charged conditions. This recommendation is based on local solar irradiation and overall efficiency of the PV power supply system as shown in Figure 6. The calculated overall efficiency considered energy losses in the control system (charge controller and pure sine wave inverter). Average efficiencies of

day-1 and day-2 were 10.93% and 9.31% respectively. Average overall efficiency of the 48-hours test was found to be 10.12%. Figure 6 also shows surface temperature of the PV panels during the test.



**Figure 6.** Energy efficiency of solar PV power supply system and the panel surface temperature

Further development of energy efficient refrigerator and chest freezer integrated with phase change materials as thermal storage [20,21] would effectively improve the potential use of solar chest freezer. Recently, the use of bio-PCM in refrigeration system which may also be integrated in this solar chest freezer has also reported in [22-25]. This technology may optimize the use of solar energy in refrigeration sector.

## 5. Conclusions

A PV-powered chest freezer has been developed to experimentally investigate the potential use of PV power supply system for a chest freezer based on Indonesia or more specifically Bali island weather conditions. The system comprises a solar PV power supply system of 300 Wp with 100 Ah battery storage and a chest freezer system specified for 100 W 220 VAC power input. The solar PV power supply system could generate electrical energy that was just enough to satisfy energy consumed by the chest freezer accounted for 1450 Wh per day generation efficiency of 10.1%. The study also found that in order to ensure continuous operation of a 100 W chest freezer and make it to be fully powered by renewable energy source, the solar PV system capacity should be 400 Wp which is about four times of the specified power input of the chest freezer.

## References

- [1] Feron S 2016 Sustainability of Off-Grid Photovoltaic Systems for Rural Electrification in Developing Countries: A Review *Sustainability* **8**, 1326.
- [2] Foley G 1995 Photovoltaic Applications in Rural Areas of the Developing World, World Bank Technical Paper *Energy Series*, number 304, 102 pgs.
- [3] Santika W, Sudirman and Suamir I N 2016 Feasibility analysis of grid/wind/PV hybrid systems for industrial application *ARPN J Eng Appl Sci* **11**, 857-862
- [4] Aktacir M A 2011 Experimental study of a multi-purpose PV-refrigerator system *International J Phys Sci* **6**, 746-757.
- [5] Elias M S and Yilma T B 2019 Modelling and performance analysis of directly coupled vapor compression solar refrigeration system Author links open overlay panel *Solar Energy* **190**, 228-238.
- [6] Suamir I N 2014 Solar driven absorption chiller for medium temperature food refrigeration, a study for application in Indonesia *Appl Mech Mater* **493**, 167-172.



- [7] He H, Wang L, Yuan J, Wang Z, Fu W, and Liang K 2019 Performance evaluation of solar absorption-compression cascade refrigeration system with an integrated air-cooled compression cycle *Energy Convers Manag* **201**, 112153.
- [8] Bellos E and Tzivanidis C 2017 Optimum design of a solar ejector refrigeration system for various operating scenarios *Energy Convers Manag* **154**, 11-24.
- [9] Fellah A, Boukhchana Y, and Brahim A B 2019 Quasi-real performances of an irreversible solar absorption refrigeration cycle *Int J Refrig* **100**, 21-26.
- [10] Wang Y, Li M, Ji X, Yu Q, Li G, and Ma X 2018 Experimental study of the effect of enhanced mass transfer on the performance improvement of a solar-driven adsorption refrigeration system *Appl Energy* **224**, 417-425.
- [11] Chena Q F, Dua S W, Yuana Z X, Sunb T B, and Lia Y X 2018 Experimental study on performance change with time of solar adsorption refrigeration system *Appl Therm Eng* **138**, 386-393.
- [12] Rumbayan M, Abudureyimu A, Nagasaka K 2012 Mapping of solar energy potential in Indonesia using artificial neural network and geographical information system *Renew Sustain Energy Rev* **16**, 1437-1449.
- [13] Veldhuis A J, and Reinders A H M E 2015 Reviewing the potential and cost-effectiveness of off-grid PV systems in Indonesia on a provincial level *Renew Sustain Energy Rev* **52**, 757-769.
- [14] Yudiantono, Anindhita, Sugiyono A, Wahid L M A and Adiarso 2018 Indonesia Energy Outlook 2018. Center for Energy Resources Development Technology. Agency for the Assessment and Application of Technology, p. 117.
- [15] FAO 2016 The State of World Fisheries and Aquaculture 2016. Contributing to food security and nutrition for all. Rome. 200 pp.
- [16] MMAF-RI 2016 Capture and aquaculture production 2012-2016. Ministry of Marine Affairs and Fisheries Republic of Indonesia. Available at: <http://statistik.kkp.go.id/sidatik-dev/2.php?x=2>
- [17] IARW 2016 Global cold storage capacity report: Capacity and growth of refrigerated warehousing by country, International Association of Refrigerated Warehouses.
- [18] ASHRAE 2017 Fundamental Handbook American Society of Heating, Refrigerating and Air-Conditioning Engineers, Inc. 1791 Tullie Circle NE, Atlanta
- [19] Kumar S 2016 Assessment of renewables for energy security and carbon mitigation in Southeast Asia: The case of Indonesia and Thailand *Appl Energy* **163**, 63-70.
- [20] Azzouz K, Leducq D, Gobin D 2009 Enhancing the performance of household refrigerators with latent heat storage: an experimental investigation *Int J Refrig* **32**, 1634-44.
- [21] Raеisi A, Suamir I N, Tassou S A 2013 Energy storage in freezer cabinets using phase change materials *Proc. the 2<sup>nd</sup> IIR International Cold Chain Conference*, Paris, pp. 187-194.
- [22] Suamir I N, Rasta I M, Sudirman and Tsamos K M 2019 Development of Corn-Oil Ester and Water Mixture Phase Change Materials for Food Refrigeration Applications *Energy Procedia* **161**, 198-206.
- [23] Rasta I M and Suamir I N 2019 Study on Thermal Properties of Bio-PCM Candidates in Comparison with Propylene Glycol and Salt Based PCM for sub-Zero Energy Storage Applications *IOP Conf. Series: Mater Sci Eng* **494**, 012024
- [24] Rasta I M and Suamir I N 2018 Development of Corn-Oil Ester and Water Mixture Phase Change Materials for Low Temperature Refrigeration Applications *Atlantis Highlights in Engineering (AHE)* **1**, 1017-1022.
- [25] Rasta I M and Suamir I N 2018 The role of vegetable oil in water based phase change materials for medium temperature refrigeration *J Energy Storage* **15**, 368-378.

### Acknowledgements

Authors acknowledge the financial support from the Ministry of Research, Technology and Higher Education of the Republic of Indonesia and Bali State Polytechnic through International Collaboration and Publication Research Scheme.