

EXPERIMENTAL INVESTIGATION OF A REHEATING TWO-STAGE ADSORPTION CHILLER APPLYING FIXED CHILLED WATER OUTLET CONDITIONS

I. Gusti Agung Bagus Wirajati,^{1,3,*} Atsushi Akisawa,¹
Yuki Ueda,¹ & Takahiko Miyazaki²

¹Graduate School of Bio-Applications and Systems Engineering,
Tokyo University of Agriculture and Technology, 2-24-16 Naka-cho,
Koganei-shi, 184-8588, Tokyo, Japan

²Faculty of Engineering Sciences, Department of Energy and Material
Sciences, Heat and Mass Transport Processes Laboratory, 6-1 Kasugo Koen,
Kasuga-shi, Fukuoka 816-8580, Japan

³Bali State Polytechnic, Bukit Jimbaran, Kuta Selatan, Bali 80364

*Address all correspondence to I. Gusti Agung Bagus Wirajati
E-mail: agungwira2@yahoo.com

The adsorption refrigeration chiller is environmentally friendly because of the use of a natural refrigerant and the use of a low-grade thermal energy as the driving energy source. In this paper, an experimental investigation of a reheating two-stage adsorption chiller was conducted, and the working principle of the cycle was also introduced. The coefficient of performance and the cooling capacity were calculated to analyze the performance of the chiller. Our objective was to identify the effect of the temperature of the heat source and the effect of cycle time on the performance if the chilled water outlet temperature is fixed at 9°C during the experiment. Experimental results showed that the performance of the chiller improved with increasing heat source temperature and that a total cycle time between 2000 to 2500 s yields better performance for the chiller.

KEY WORDS: reheating adsorption chiller, fixed chilled water outlet temperature, COP, cooling capacity

1. INTRODUCTION

The adsorption refrigeration chiller has sustained an increased interest over the past three decades. The adsorption refrigeration chiller system is regarded not only as an alternative cooling system for reducing the use of chlorofluorocarbons (CFCs) and hydrofluorocarbons (HCFCs) but also as an energy-efficient technology (Dieng and

NOMENCLATURE			
c_w	isobaric specific heat of water,	Subscripts	
	J/kg K	ads	adsorption
COP	coefficient of performance	chill	chiller
\dot{m}	mass flow rate, kg/s	con	condenser
P	pressure, kPa	des	desorption
Q	heat transfer, kJ	evap	evaporator
T	temperature, °C	in	inlet
t	time, s	mr	mass recovery
HEX	heat exchanger	out	outlet
P–T–X	pressure, temperature,	ph	preheating
	concentration	pc	precooling

Wang, 2001). Recently, the system has been considered promising due to the use of a low-grade heat source temperature. Many theoretical and experimental investigations have been conducted not only on a single-stage (conventional stage) chiller but also on the advanced-stage operational chillers (Farid et al., 2011; Lu et al., 2011; Rezk and Al-Dadah, 2012; Xia et al., 2009; Uyun et al., 2009; Miyazaki and Akisawa, 2009). The reheating two-stage adsorption chiller is one of the advanced stages of the adsorption chiller. Saha et al. (2003) investigated the performance of a thermally activated silica gel–water adsorption refrigeration cycle by applying a multibed scheme. Boelman et al. (1995) experimentally evaluated the commercial two-bed adsorption chiller under a typical cyclic steady-state operation. Chua et al. (2001) investigated the improvement of the utilization of waste heat and reduction of the chilled water outlet temperature fluctuation. Ng et al. (2006) and Wang et al. (2007) also investigated the performance of the adsorption chiller experimentally, but the temperature of the chilled water outlet was not fixed. The reheating two-stage adsorption chiller has also been investigated experimentally. Alam et al. (2007) investigated the performance of the chiller and compared the reheating two-stage adsorption chiller with the conventional single- and two-stage chillers. The chilled water outlet in this experiment operated with fluctuating temperatures. Khan et al. (2007) also investigated the reheating two-stage adsorption chiller, but the temperature of the chilled water outlet was not fixed.

Maintaining a constant chilled water outlet temperature is also of equal importance to improve the conversion efficiency of the chiller so that a maximum cooling capacity can be delivered (Tong et al., 2001). However, maintaining a constant chilled

water outlet temperature during the experiments is difficult because the outlet water temperature cannot be set up automatically. From this point of view, the main objective of this investigation was to identify the effects of the heat source temperature and cycle time on the performance while the chilled water outlet temperature was kept constant at 9°C. The total cycle times of 1000 s and 2500 s are representative of the reheating adsorption chiller with short and long cycles. Understanding of the short and long cycles is based on how long (time is in seconds) the cycle time is applied in the experiment.

2. WORKING PRINCIPLE OF REHEATING TWO-STAGE ADSORPTION CHILLERS

Figure 1a shows the schematic diagram of a reheating two-stage adsorption chiller, while Fig. 1b shows the P–T–X diagram for standard conditions. The chiller consists of four heat exchangers (i.e., HEX1, HEX2, HEX3, and HEX4), two evaporators, and two condensers. The adsorbent heat exchangers of the chiller are operated through six thermodynamic processes in a full cycle, namely, adsorption (1-2), mass recovery with cooling (2-3), preheating (3-4), desorption (4-5), mass recovery with heating (5-6), and precooling (6-1). In the adsorption process, a refrigerant (water) is evaporated in the evaporator and the temperature (T_{eva}) and heat (Q_{eva}) are taken isobarically from the chilled water. An evaporation process occurs and produces a cooling effect. Heat for the evaporation of the water is supplied by flowing chilled water at a low heat source temperature. In the first half cycle, HEX1 is heated by hot water and HEX3 is cooled by cooling water. When the pressures of HEX1 and HEX3 are nearly equal, both are then connected by opening the connecting valve, allowing the vapor to flow from HEX1 into HEX3. This process is known as the mass recovery process. Heating and cooling processes are continued during the mass recovery process. HEX1 is heated by hot water, and HEX3 is cooled by cooling water to provide more cooling capacity. During this process, refrigerant circulation is stopped by closing all refrigerant valves. This process is known as the preheating/precooling process.

When the pressures of HEX1 and HEX3 are nearly equal to the pressures of the condenser and evaporator, the valve between HEX1 and the condenser (as well as the valve between HEX3 and the evaporator) is opened, allowing the refrigerant to flow. The adsorption and desorption process then begins. In this process, the refrigerant from HEX1 is transferred to the condenser, and then it will condense by releasing heat to the heat sink.

Finally, the liquid refrigerant flows from the condenser to the evaporator through a U-shaped tube to control the pressure differential between the condenser and evaporator. To complete one cycle, the next part of the process is the same as the first half-cycle, but HEX3 is the desorber and HEX1 is the adsorber. HEX2 and HEX4 also follow a process similar to HEX 1 and HEX 3 in the full cycle.

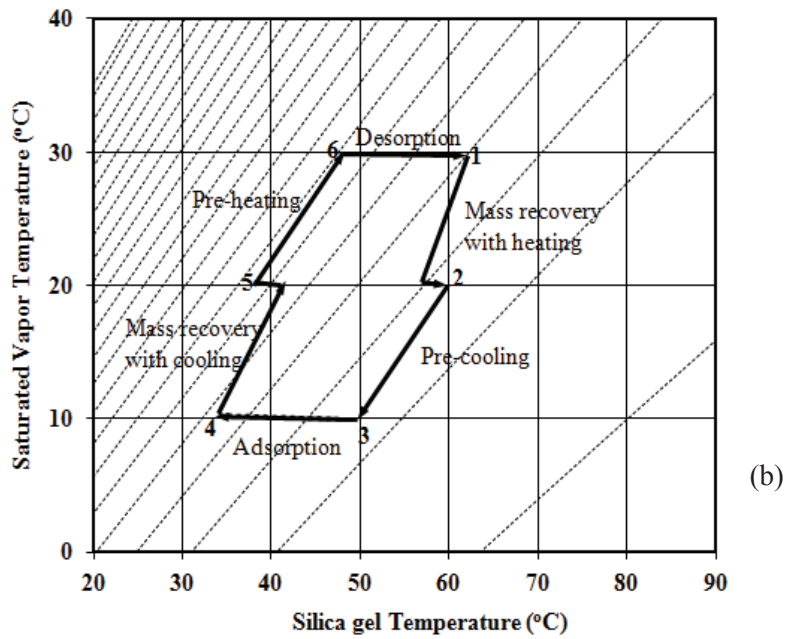
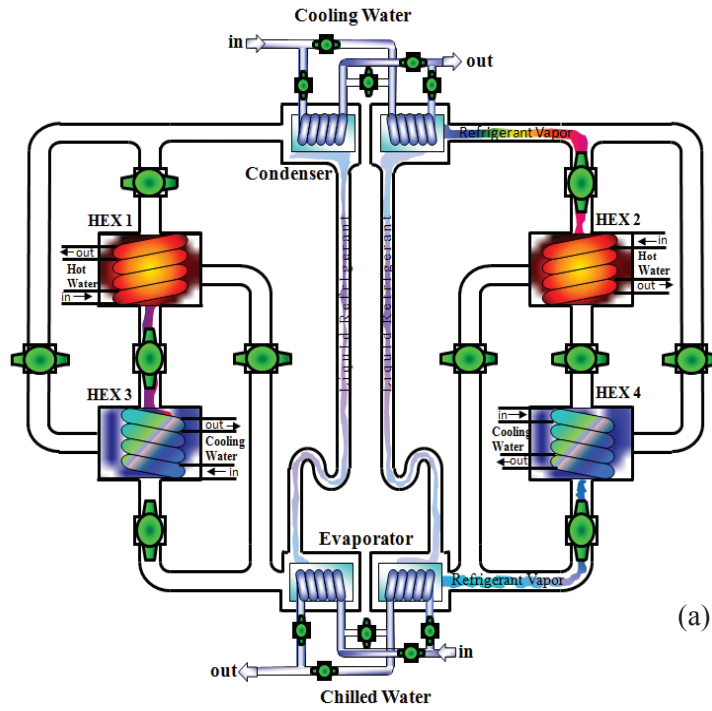

FIG. 1: (a) Reheating two-stage adsorption chiller scheme; (b) P-T-X diagram

3. EXPERIMENTAL PROCEDURE FOR THE REHEATING TWO-STAGE ADSORPTION CHILLER

3.1 Experimental Apparatus

The experimental setup of the reheating two-stage adsorption chiller, which has been installed in the laboratory of the Tokyo University of Agriculture and Technology, is shown in Fig. 2. The experimental setup is designed to test various operating modes of the adsorption cycle. The chiller has six adsorption/desorption heat exchangers (HEXs), two condensers, and two evaporators. Though the chiller has six HEXs, only four HEXs (i.e., HEX1, HEX2, HEX5, and HEX6) were used in this experiment, with the other two HEXs (i.e., HEX3 and HEX4) being not used. The chiller also has three types of reservoir tanks that have been installed outside the room, namely, a hot water tank, a cooling water tank, and a chilled water tank. Silica gel type A, which consists of spherical particles 2–20 nm in size, and water are used as the adsorbent/refrigerant pair in this chiller.

Table 1 shows the chiller operating strategy to complete one full cycle of the reheating two-stage chiller. The cycle consists of ten operational modes (A–J). There are two pairs of HEXs: one pair is HEX1 and HEX 5, and the other pair is HEX 2

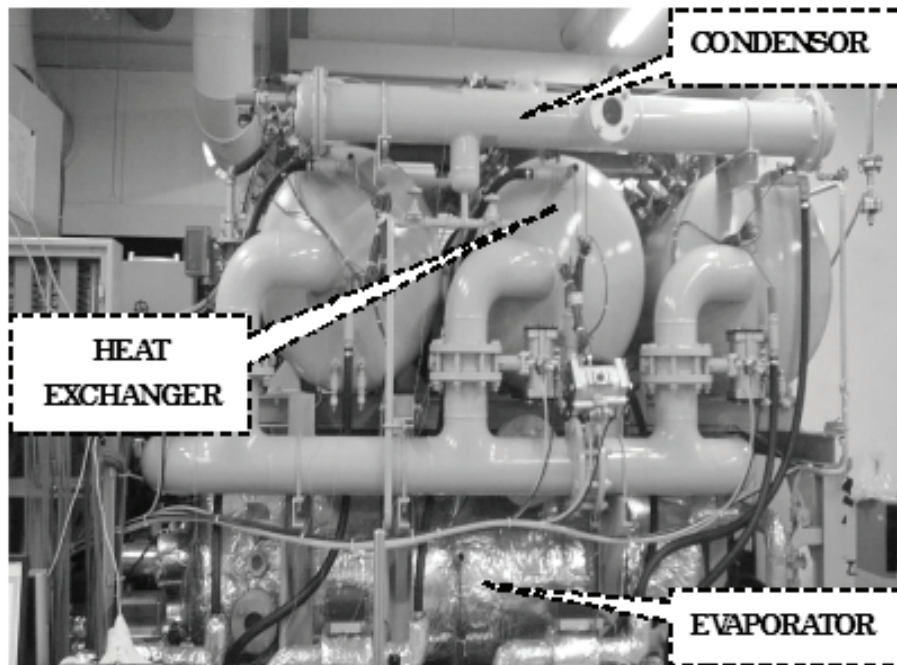

FIG. 2: The experimental adsorption chiller

TABLE 1: Chiller operating strategy of the reheating two-stage chiller

HEX	Mode									
	A	B	C	D	E	F	G	H	I	J
1	Des			Mrh	Pc	Ads			Mrc	Ph
2	Mrh	Pc	Ads			Mrc	Ph	Des		
5	Ads			Mrc	Ph	Des			Mrh	Pc
6	Mrc	Ph	Des			Mrh	Pc	Ads		

Ads = adsorption, Mrh = mass recovery on heating, Pc = precooling, Des = desorption, Mrc = mass recovery on cooling, Ph = preheating

and HEX6. The mass recovery process occurs between each pair. In the first half-cycle, when one pair of HEXs (1 and 5) is in the desorption–adsorption process (mode A to C), at the same time, another pair of HEXs (2 and 6) is completing the mass recovery process (mode A) and the preheating/precooling process (mode B). After one HEX pair (2 and 6) has gone into the adsorption–desorption process (mode C to F), at the same time, the other HEX pair (1 and 5) is completing the mass recovery process (mode D) and the precooling/preheating process (mode E). In the second half-cycle (i.e., mode F to mode J), the HEX pair (1 and 5) acts in the same way as the HEX pair (2 and 6) and vice versa. In mode C and mode H, there are two HEX pairs undertaking the adsorption–desorption process simultaneously.

3.2 Instrument and Test Procedures

Three types of measurements were performed in the experiment for the temperature, pressure, and mass flow rate. The concentration of a refrigerant in the HEXs cannot be measured directly, so that parameter was approached using the temperature and HEX pressure calculations. In HEXs, thermocouple sensors are used to measure the temperature of the HEXs, refrigerant vapor, and the inlet–outlet water temperature.

Similarly, in condensers and evaporators, thermocouple sensors were also used to measure the temperature of the condenser and evaporator, the inlet–outlet temperature of the condensers, and the inlet–outlet temperature of the chilled water. Pressure sensors were used to measure the pressures of the HEX, condenser, and evaporator. Electromagnetic flow meters are used to measure the flow rate of the cooling water and the heating water of the HEXs, the flow rate of the cooling water into the condenser, and the flow rate of chilled water into the evaporator. All sensors were connected to a data logger, and the measurements were performed every second. A computer was used to save the measured data. The position of the measurement point is marked in Fig. 3.

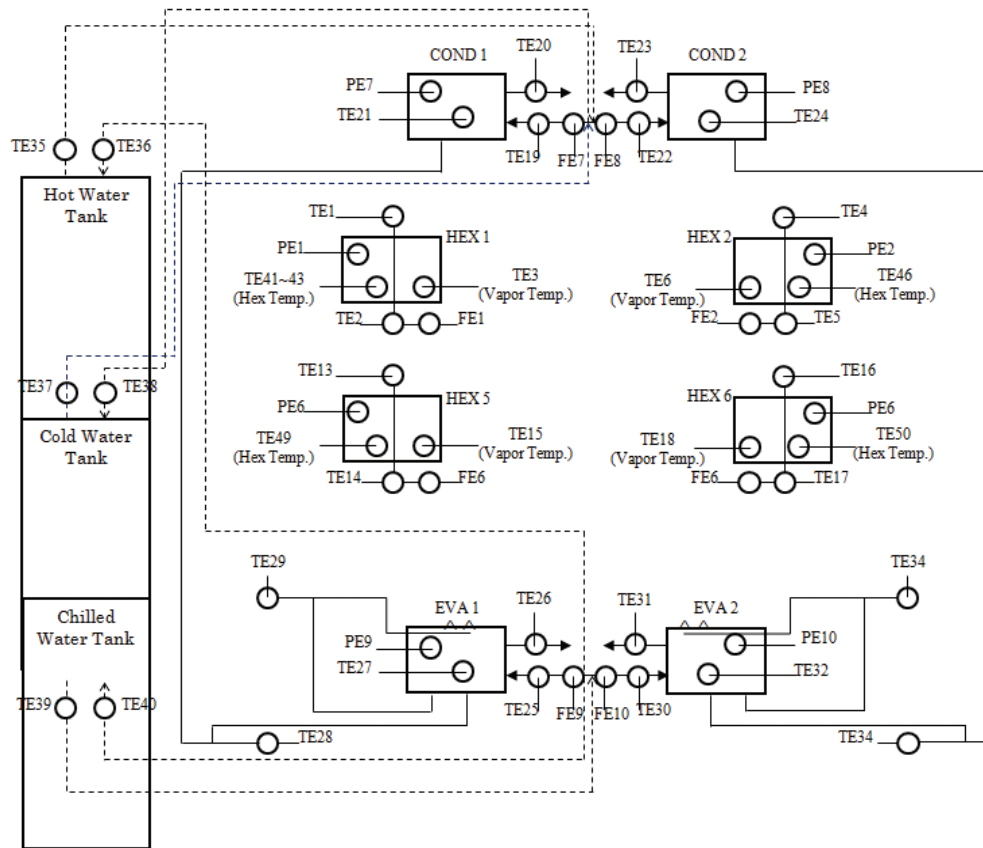

FIG. 3: Measurement point on a four-HEXs chiller

3.3 Parameter Settings

Table 2 presents the standard experimental parameters applied during the experiment. The important point of the experiment was that the chilled water outlet temperature was maintained constant at 9°C. Applying this extent of control over this parameter required extra attention during the experiment because the chilled water outlet temperature cannot be set up automatically on the machine. The chilled water outlet temperature was controlled by adjusting the flows for the chilled water outlet temperature. The cycle time parameters (in Table 3) were distributed in every mode based on Table 1 to observe the effect of cycle time on the performance.

4. PERFORMANCE INDICATOR INDEX

The performance of the reheating two-stage adsorption chiller is indicated mainly by the coefficient of performance (COP) and the cooling capacity (CC), which can be examined as follows.

TABLE 2: Standard experimental conditions

Parameter		Value	Unit
Hot water	Temperature	60, 65, 70, 75	°C
	Flow rate	1.8	kg/s
Cooling water in	Temperature	30	°C
	Flow rate	1.4	kg/s
Chilled water in	Temperature	14	°C
	Flow rate	0.17	kg/s
Chilled water out	Temperature	9	°C
	Flow rate	0.1-0.4	kg/s

TABLE 3: Parameter condition

Two-stage reheating										
A	B	C	D	E	F	G	H	I	J	Cycle time (s)
100	30	240	100	30	100	30	240	100	30	1000
200	30	290	200	30	200	30	290	200	30	1500
300	30	340	300	30	300	30	340	300	30	2000
400	30	390	400	30	400	30	390	400	30	2500
500	30	440	500	30	500	30	440	500	30	3000
600	30	490	600	30	600	30	490	600	30	3500
700	30	540	700	30	700	30	540	700	30	4000
Single stage										
420	30	420	30							900

4.1 Coefficient of Performance

During the heating mode, the heat input from the heat source (Q_{in}) is the heat input into the generator and can be estimated as:

$$Q_{in} = \dot{m}_{hot} C_w \int_0^{t_{cycle}} (T_{hot_{in}} - T_{hot_{out}}) dt. \quad (1)$$

The heat released by the evaporator (Q_{evap}) is the heat entering the evaporator and can be expressed as

$$Q_{\text{evap}} = \dot{m}_{\text{chill}} C_w \int_0^{t_{\text{cycle}}} (T_{\text{chill}_{\text{in}}} - T_{\text{chill}_{\text{out}}}) dt \quad (2)$$

The COP can be written as the ratio between the heat released by the evaporator and the heat input:

$$\text{COP} = \frac{Q_{\text{eva}}}{Q_{\text{in}}} \quad (3)$$

4.2 Cooling Capacity

The cooling capacity is the average of the heat released by the evaporator in one cycle process and can be written as

$$CC = \dot{m}_{\text{chill}} C_w \int_0^{t_{\text{cycle}}} (T_{\text{chill}_{\text{in}}} - T_{\text{chill}_{\text{out}}}) \frac{dt}{t_{\text{cycle}}} \quad (4)$$

where \dot{m}_{hot} , \dot{m}_{chill} , T_{hot} , and T_{chill} are the hot water mass flow rate, chilled water mass flow rate, hot water temperature, and chilled water temperature, respectively, C_w denotes the isobaric specific heat of water (4180 J/kg K). The quantities t_{cycle} and dt denote the cycle time and time interval (s), respectively. The suffixes 'in' and 'out' refer to inlet and outlet water flows.

5. RESULTS AND DISCUSSION

5.1 Temperature and Pressure Histories

Figure 4 illustrates the temperature histories of the four HEXs of the chiller with the heat source temperature at 60°C and a total cycle time of 2000 s. In the beginning (300 s), HEX2 and HEX6 are in the mass recovery process, HEX2 is in the heating mode, and HEX6 is in the cooling mode (mode A). At the beginning, the temperature and pressure of HEX2 decrease and that of HEX6 increase suddenly after the temperature of HEX2 is increased and HEX6 is decreased due to heating by hot water and cooling by cool water. As a result, HEX2 starts to desorb and HEX6 to adsorb water vapor very fast. In mode B, HEX2 is in the precooling process and HEX6 is in the preheating process. The temperature of HEX2 decreases and the pressure declines. The temperature and pressure of HEX6 increase. The next process is the desorption process for HEX2 and the adsorption process for HEX6 (modes C, D, and E). In this process, HEX2 operates on the evaporator pressure and HEX6 operates on the condenser pressure. The refrigerant in the evaporator will be evaporated and adsorbed by HEX2. At the same time, the adsorbed refrigerant of HEX6 will be released to the condenser in the adsorption process and then condensed in the condenser. Up to mode

E is a first half-cycle, and the next process (mode F to J) is similar to mode A to E, but the adsorber and desorber positions will be changed in each of the HEX pairs, which is shown in Fig. 4.

Figure 5 shows that the pressure and temperature of condenser 1 increase drastically when the condensation process begins or when condenser 1 is connected to the HEX. The rate of heat from the refrigerant vapor received by the condenser is not equal to the rate of heat adsorbed by the cooling condenser. The increase occurs until a certain point when the released refrigerant is condensed in the condenser in large quantities. After exceeding the maximum point, the pressure and temperature of condenser 1 will start to

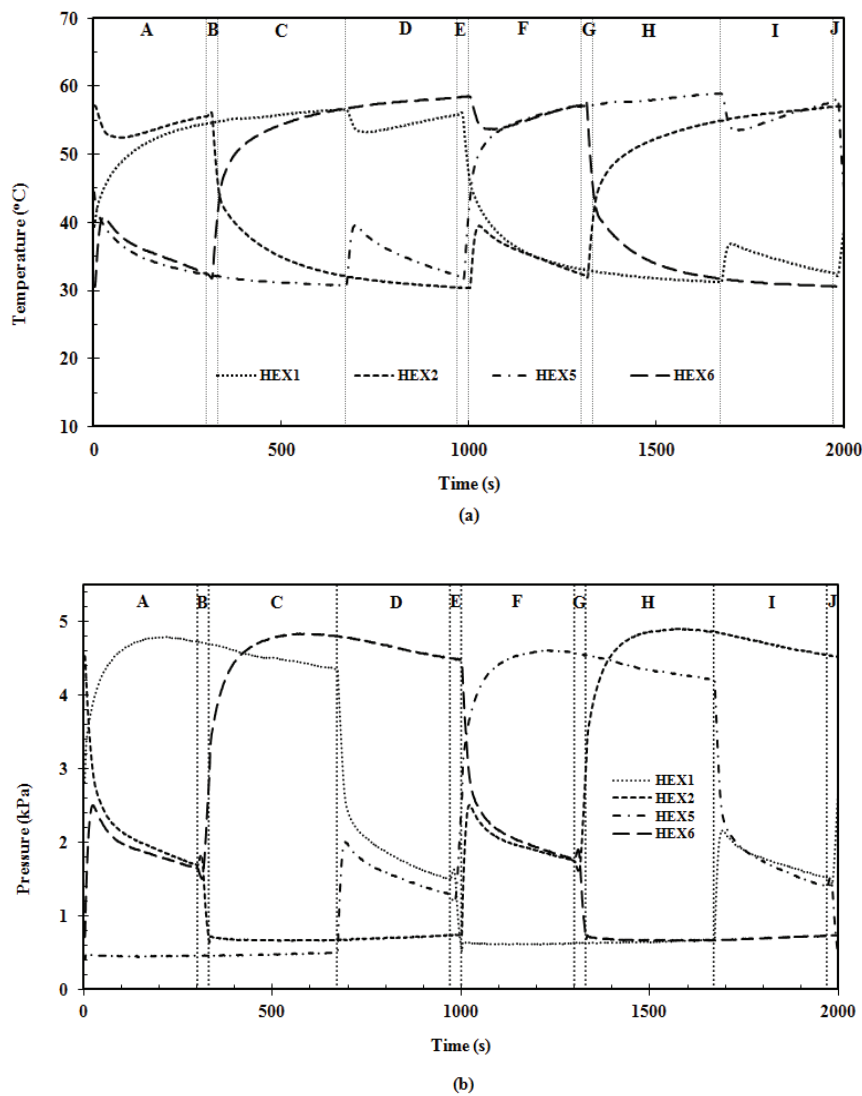

FIG. 4: Temperature (a) and pressure (b) histories of heat exchangers of the chiller

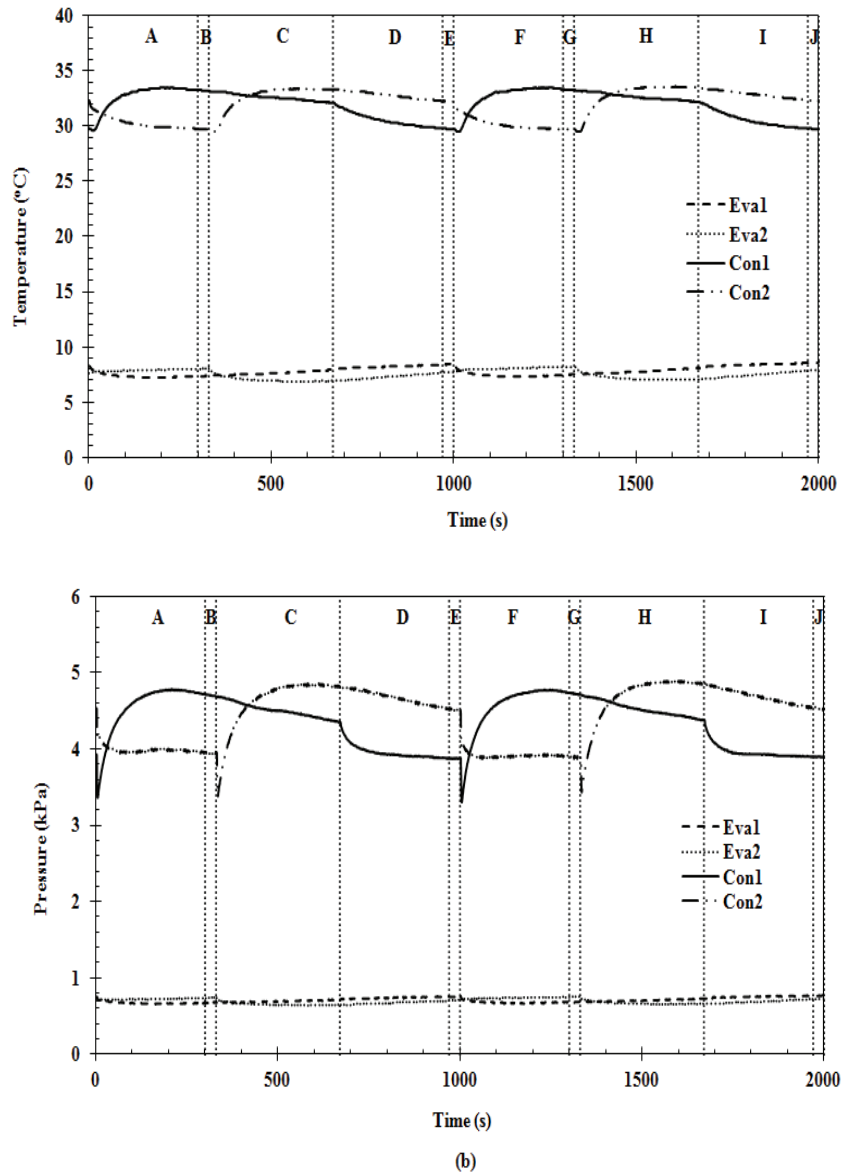

FIG. 5: Temperature (a) and pressure (b) histories of condenser and evaporator of the chiller

decrease, while the pressure and temperature of condenser 2 will start to increase. The trend of evaporator temperature and pressure is the opposite trend of the condenser. When the evaporator is used during the evaporation process, the temperature as well as the pressure decrease until a minimum point and then increase.

5.1 Effect of Heat Source Temperature on Performance

The effect of the temperature of the heat source on performance is shown in Fig. 6a, where the chilled water outlet temperature was 9°C and the total cycle time was

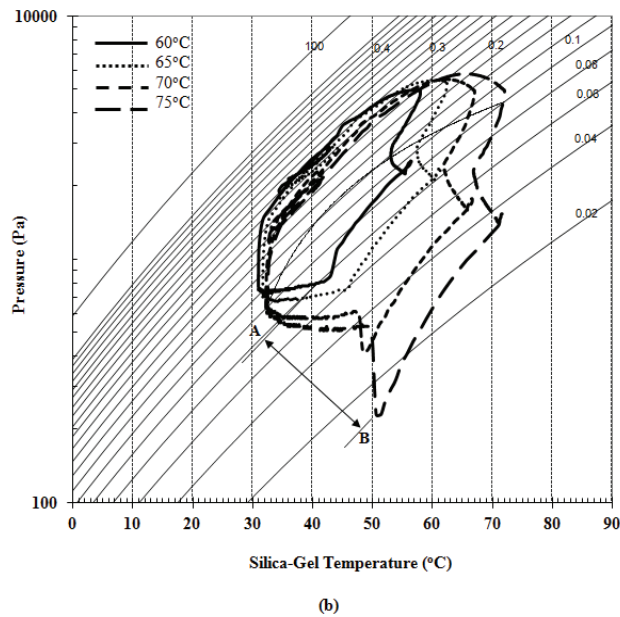
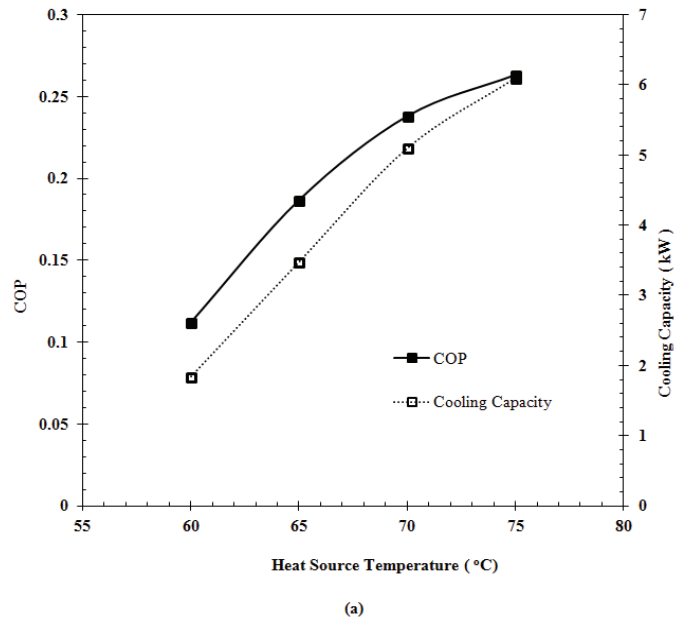

FIG. 6: Effect of the heat source temperature on: a) performance; b) P–T–X diagram

1300 s. The COP and cooling capacity both increased with the heat source temperature.

The reason that the COP and cooling capacity both increased with the heat source temperature is explained in Fig. 6b, which shows that the concentration difference increases from point A to B if the heat source temperature increases. As the difference between the maximum and minimum concentration levels expands with increase in the heat source temperature, the cooling capacity as well as the COP improves with increase in the heat source temperature. A greater amount of refrigerant will therefore be adsorbed and desorbed.

5.3 Effect of Cycle Time on Performance

The effect of the cycle time on performance (the COP and cooling capacity) is shown by Fig. 7a. Seven cycle times are chosen from 1000 s to 4000 s to represent the short cycle and the long cycle (Table 3). The experimental conditions were set up with the heat source temperature and chilled water outlet temperature at 60°C and 9°C, respectively.

The highest levels of performance were attained between cycle times of 2000–2500 s. When cycle times were less than 2000 s, a sufficient time was not available for the process of adsorption/desorption. The result is therefore a low level of performance. In cycle times longer than 2500 s, the performance decreases drastically because the adsorption tends to be relatively less intense.

Longer cycle times cause more refrigerant to be adsorbed and desorbed. More cooling energy should therefore be produced in one cycle. However, an excessively long cycle will create a reduction in the average cooling power. Longer cycle times produce more cooling power with a relatively lower consumption of driving heat. The COP was therefore observed to increase uniformly within cycle times less than 2500 s. Further explanation of the effect of cycle time on the performance can be illustrated by the Duhring diagram in Fig. 7b. Two cycle times (1000 s and 2500 s) were chosen as representative of the short cycle and long cycle. Longer cycle times give sufficient time to reach the maximum–minimum concentration. The figure shows that the Duhring diagram at longer cycle times generates more expansion than the short cycle time.

5.4 Performance Comparison between the Reheating Two-Stage Chiller and the Single-Stage Chiller

A performance comparison between the reheating two-stage (short and long cycle) chiller and the single-stage chiller is presented in Fig. 8. The parameter conditions based on Table 3 were applied during the experiment. The four heat exchangers were used for a single-stage cycle comparing the performance between the chillers.

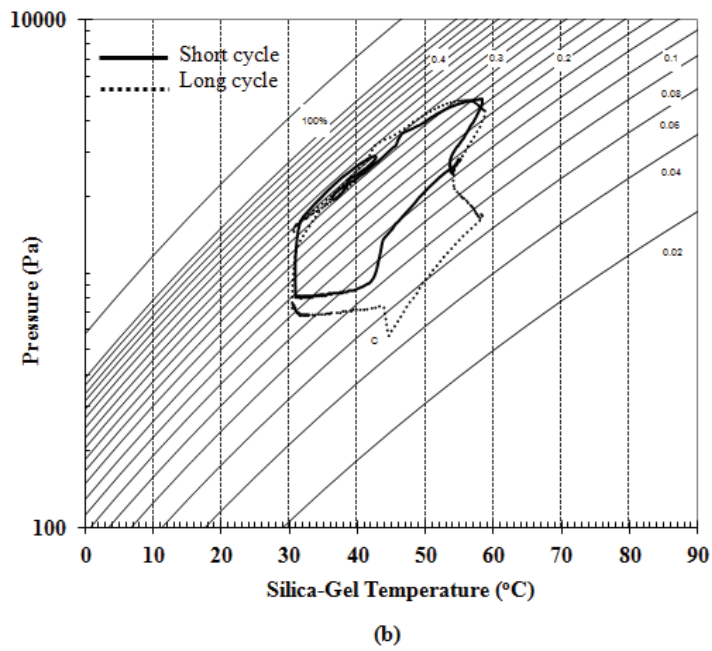
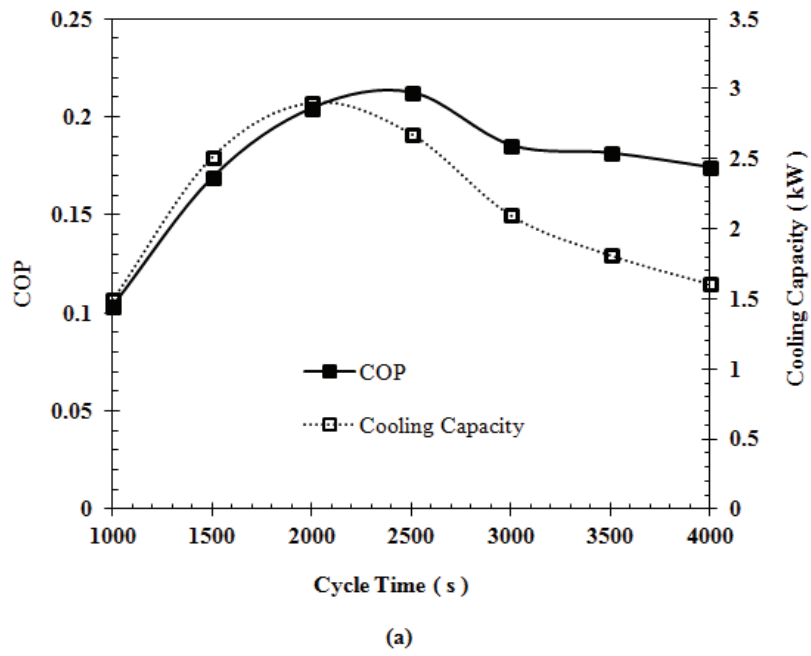
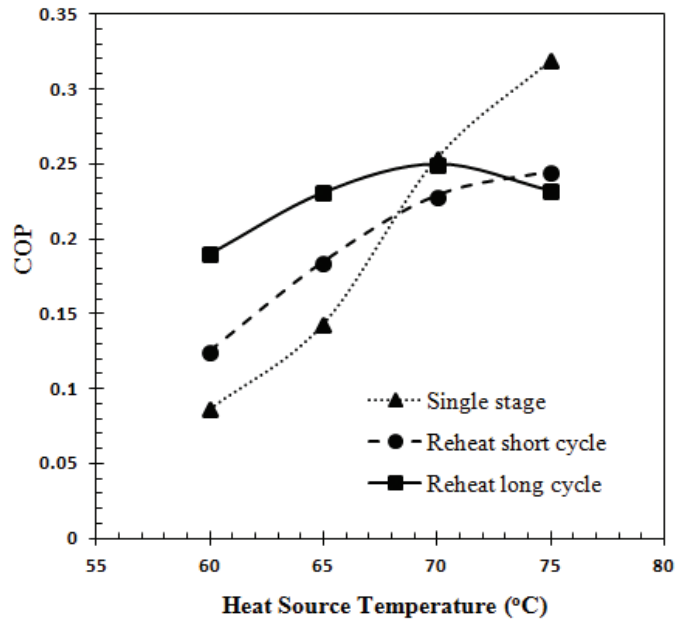
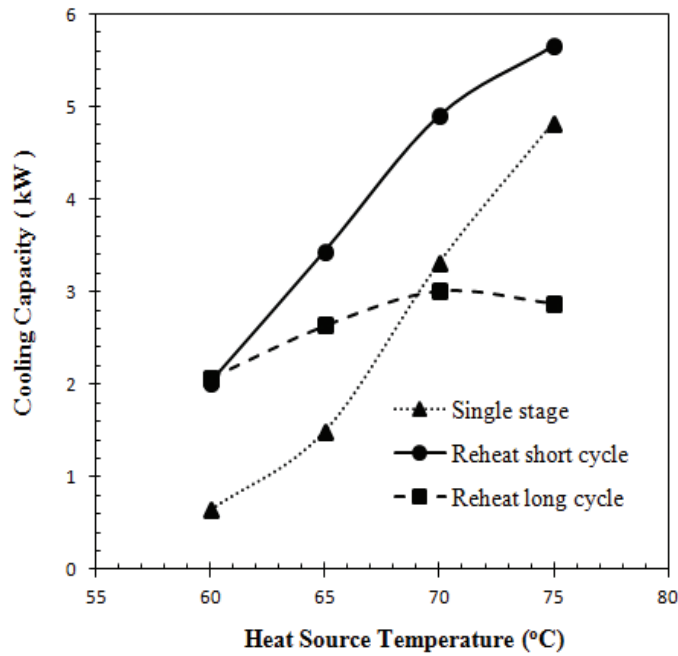

FIG. 7: (a) Effect of the cycle time on: a) performance; b) P-T-X diagram



(a)



(b)

FIG. 8: Performance comparison among the short reheating, long reheating, and single stage

Based on Fig. 8, the reheating two-stage chiller with a long cycle provides better COP values than a short cycle time and a single stage. The COP expanded with the cycle time because the adsorption chiller with a long cycle time produced a relatively higher cooling effect. According to the figure, the cycle time is responsive to the heat source temperature. For a low heat source temperature, the COP value for the reheating adsorption cycle with a long cycle time is better than the reheating short cycle and single stage. For a high heat source temperature, the COP of the single stage is superior.

The cooling capacity obtained from the reheating adsorption cycle with the long cycle and the short cycle is better than the single stage with a low heat source temperature. However, the short cycle time offered better cooling capacity with a relatively high heat source temperature compared to the other cycle.

6. CONCLUSIONS

The following concluding remarks can be drawn from the present study:

- (i) the heat source temperature and cycle time are the influential factors for the reheating two-stage cycle chiller;
- (ii) the performance of the chiller increased with increasing heat source temperature;
- (iii) a total cycle time of 2000 s to 2500 s gives better performance for the chiller;
- (vi) for a relatively low heat source temperature, both short cycles and long cycles of the reheating two-stage cycle chiller offer better performance than the single-stage chiller.

REFERENCES

- Alam, K. C. A., Khan, M. Z. I., Uyun, A. S., Hamamoto, Y., Akisawa, A., and Kashiwagi, T., Experimental study of a low temperature heat driven re-heat two-stage adsorption chiller, *Appl. Thermal Eng.*, vol. **27**, pp. 1686–1692, 2007.
- Boelman, E. C., Saha, B. B., and Kashiwagi, T., Experimental investigation of a silica gel–water adsorption refrigeration cycle — the influence of operating conditions on cooling output and COP, *ASHRAE Trans: Res.*, vol. **101**, no. 2, pp. 358–366, 1995.
- Chua, H. T., Ng, K. C., Malek, A., Kashiwagi, T., Akisawa, A., and Saha, B. B., Multi-bed regenerative adsorption chiller — improving the utilization of waste heat and reducing the chilled water outlet temperature fluctuation, *Int. J. Refrig.*, vol. **24**, pp. 124–136, 2001.
- Dieng, A. O., and Wang, R. Z., Literature review on solar adsorption technologies for ice-making and air-conditioning purposes and recent developments in solar technology, *Renew. Sustain. Energy Rev.*, vol. **5**, pp. 313–342, 2001.
- Farid, S. K., Billah, M. M., Khan, M. Z. I., Rahman, M. M., and Sharif, U. M., A numerical analysis of cooling water temperature of two-stage adsorption chiller along with different mass ratios, *Int. Commun. Heat Mass Transfer*, vol. **38**, pp. 1086–1092, 2011.
- Khan, M. Z. I., Alam, K. C. A., Saha, B. B., Akisawa, A., and Kashiwagi, T., Study on a re-heat two-stage adsorption chiller — The influence of thermal capacitance ratio, overall thermal conductance ratio and adsorbent mass on system performance, *Appl. Thermal Eng.*, vol. **27**, pp. 1677–1685, 2007.

- Lu, Z. S., Wang, R. Z., Xia, Z. Z., Wu, Q. B., Sun, Y. M., and Chen, Z. Y., An analysis of the performance of a novel solar silica gel–water adsorption air conditioning, *Appl. Thermal Eng.*, vol. **31**, pp. 3636–3642, 2011.
- Miyazaki, T. and Akisawa, A., The influence of heat exchanger parameters on the optimum cycle time of adsorption chillers, *Appl. Thermal Eng.*, vol. **29**, pp. 2708–2717, 2009.
- Ng, K. C., Wang, X., Lim, Y. S., Saha, B. B., Chakarborty, A., Koyama, S., Akisawa, A., and Kashiwagi, T., Experimental study on performance improvement of a four-bed adsorption chiller by using heat and mass recovery, *Int. J. Heat Mass Transfer*, vol. **49**, pp. 3343–3348, 2006.
- Rezk, A. R. M. and Al-Dadah R. K., Physical and operating conditions effects on silica gel/water adsorption chiller performance, *Appl. Energy*, vol. **89**, pp. 142–149, 2012.
- Saha, B. B., Koyama, S., Lee, J. B., Kuwahara, K., Alam, K. C. A., Hamamoto, Y., Akisawa, A., and Kashiwagi, T., Performance evaluation of a low-temperature waste heat driven multi-bed adsorption chiller, *Int. J. Multiphase Flow*, vol. **29**, pp. 1249–1263, 2003.
- Tong, C. H., Choon, N. K., Malek, A., Kashiwagi, T., Akisawa, A., and Saha, B. B., A regenerative adsorption process and multi reactor regenerative adsorption chiller, Espacenet Description: EP 1140314 (A1), 2001.
- Uyun, A. S., Akisawa, A., Miyazaki, T., Ueda, Y., and Kashiwagi, T., Numerical analysis of an advanced three-bed mass recovery adsorption refrigeration cycle, *Appl. Thermal Eng.*, vol. **29**, pp. 2876–2884, 2009.
- Wang, D. C., Shi, Z. X., Yang, Q. R., Tian, X. L., Zhang, J. C., and Wu, J. Y., Experimental research on novel adsorption chiller driven by low-grade heat source, *Energy Convers. Manag.*, vol. **48**, pp. 2375–2381, 2007.
- Xia, Z. Z., Wang, R. Z., Wang, D. C., Liu, Y. L., Wu, J. Y., and Chen, C. J., Development and comparison of two-bed silica gel–water adsorption chillers driven by low-grade heat source, *Int. J. Thermal Sci.*, vol. **48**, pp. 1017–1025, 2009.